

Superior Edition HELICOPTER T-REX 450SE NEW V2

KX015042TA 1K Silver 銀 / KX015043TA 3K Black 黑

INSTRUCTION MANUAL 使用說明書

325 Carbon Blade

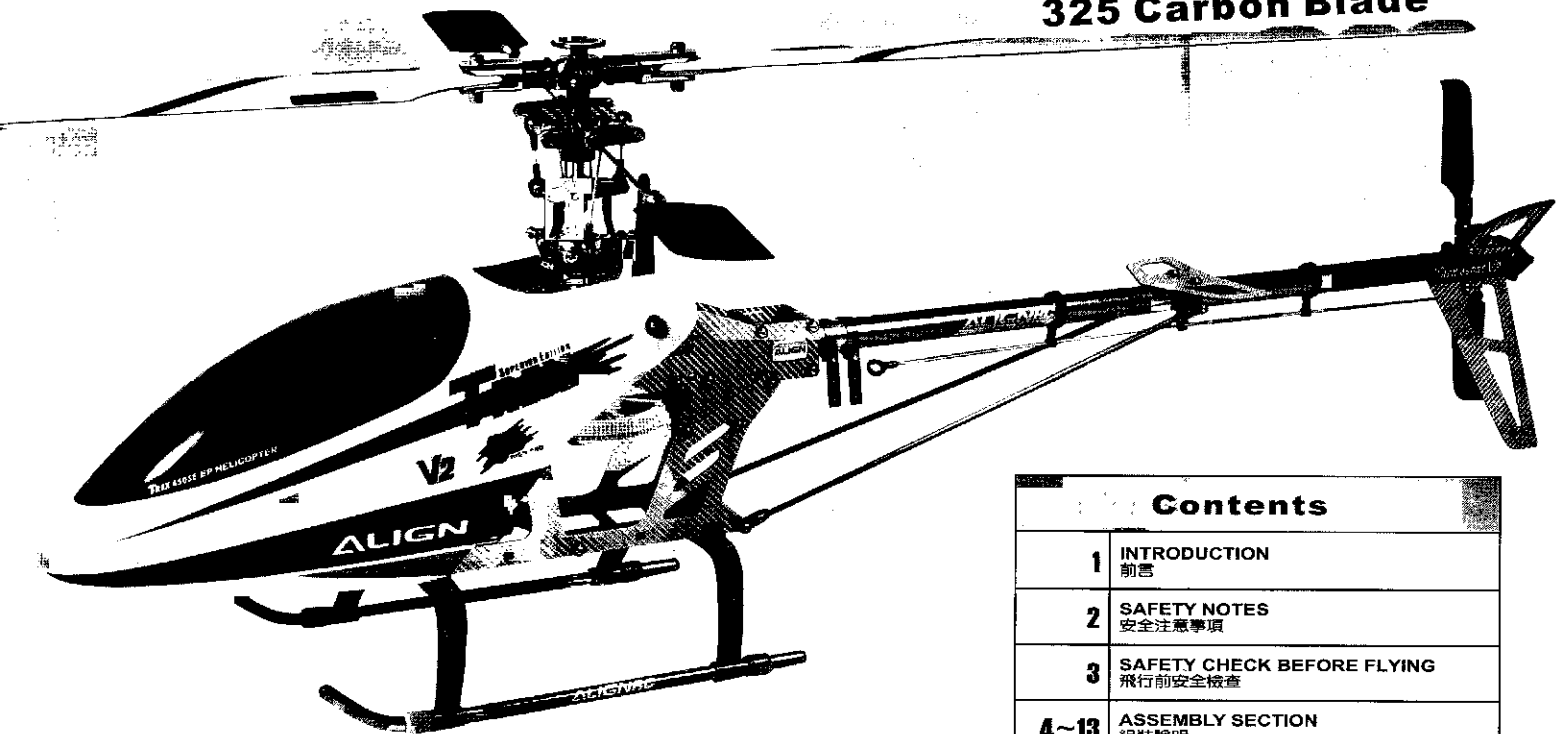

Contents	
1	INTRODUCTION 前言
2	SAFETY NOTES 安全注意事項
3	SAFETY CHECK BEFORE FLYING 飛行前安全檢查
4~13	ASSEMBLY SECTION 組裝說明
14~15	SERVO INSTALLATION 伺服器安裝
16	ELECTRONIC EQUIPMENT AND GYRO INSTALLATION 電子設備與陀螺儀建議安裝位置
17	EQUIPMENT ILLUSTRATION 設備建議配置圖示
17	MAIN ROTOR ADJUSTMENTS 主旋翼平衡與變槳校正
17	TROUBLESHOOTING THE POWER SYSTEM 動力異常檢查
18	CANOPY ASSEMBLY 機頭罩安裝
19	SERVO SETTING AND ADJUSTMENT 伺服器設定調整
19	ADJUSTMENTS FOR GYRO AND TAIL NEUTRAL SETTING 陀螺儀與尾翼中立點調整
20	PITCH AND THROTTLE SETTING 主旋翼螺距與油門設定
21	POWER COLLOCATION SUGGESTION 動力分配建議表
21	BRUSHLESS ESC SETTING SUGGESTION 無刷調速器程式設定建議
22~25	FLIGHT ADJUSTMENT AND SETTING 飛行動作調整與設定
26~33	PARTS LIST 零件明細
34	HARDWARE SIZING REFERENCE CHART (ACTUAL SIZE) 五金零件實寸比例名稱對照表



Thank you for buying ALIGN products. The T-REX 450SE NEW V2 is the latest technology in Rotary RC models. Please read this manual carefully before assembling and flying the new T-REX 450SE NEW V2 helicopter. We recommend that you keep this manual for future reference regarding tuning and maintenance.

承蒙閣下選用亞拓遙控世界系列產品，謹表謝意。進入遙控世界之前必須告訴您許多相關的知識與注意事項，以確保您能夠在學習的過程中較得心應手。在開始操作之前，請務必詳閱本說明書，相信一定能夠給您帶來相當大的幫助，也請您妥善保管這本說明書，以作為日後參考。

Thank you for buying ALIGN Products. The T-REX 450SE V2 Helicopter is designed as an easy to use, full featured Helicopter R/C model capable of all forms of rotary flight. Please read the manual carefully before assembling the model, and follow all precautions and recommendations located within the manual. Be sure to retain the manual for future reference, routine maintenance, and tuning. The T-REX 450SE V2 is a new product developed by ALIGN. It features the best design available on the Micro-Heli market to date, providing flying stability for beginners, full aerobatic capability for advanced fliers, and unsurpassed reliability for customer support.

感謝您選購亞拓產品，為了讓您容易方便的使用 T-REX 450SE V2 直昇機，請您詳細的閱讀完這本說明書之後再進行組裝以及操作這台直昇機，同時請您妥善的保存這本說明書，作為日後進行調整以及維修的參考。T-REX 450SE V2 是由亞拓自行研發的新產品，不論你是需求飛行穩定性的初學者或是追求性能的飛行愛好者。T-REX 450SE V2 將是你最佳的選擇。

THE MEANING OF SYMBOLS 標誌代表涵義

	Mishandling due to failure to follow these instructions may result in damage or injury. 因為疏忽這些操作說明，而使用錯誤可能造成財產損失或嚴重傷害。
	Mishandling due to failure to follow these instructions may result in danger. 因為疏忽這些操作說明，而使用錯誤可能造成危險。
	Do not attempt under any circumstances. 在任何禁止的環境下，請勿嘗試操作。

IMPORTANT NOTES 重要聲明

R/C helicopters, including the T-REX 450SE V2 are not toys. R/C helicopter utilize various high-tech products and technologies to provide superior performance. Improper use of this product can result in serious injury or even death. Please read this manual carefully before using and make sure to be conscious of your own personal safety and the safety of others and your environment when operating all ALIGN products. Manufacturer and seller assume no liability for the operation or the use of this product. Intended for use only by adults with experience flying remote control helicopters. After the sale of this product we cannot maintain any control over its operation or usage.

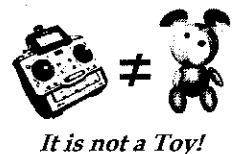

T-REX 450SE V2 遙控直昇機並非玩具，它是結合了許多高科技產品所設計出來的休閒用品，所以商品的使用不當或不熟悉都可能會造成嚴重傷害甚至死亡，使用之前請務必詳讀本說明書，勿輕忽並注意自身安全。注意！任何遙控直昇機的使用，製造商和經銷商是無法對使用者於零件使用的損耗異常或組裝不當所發生之意外負任何責任，本產品是提供給有操作過模型直昇機經驗的成人或有相當技術的人員在旁指導，以確保安全無虞下操作使用，產品售出後本公司將不負任何操作和使用控制上的任何性能與安全責任。

We recommend that you obtain the assistance of an experienced pilot before attempting to fly our products for the first time. A local expert is the best way to properly assemble, setup, and fly your model for the first time. The T-REX 450SE V2 requires a certain degree of skill to operate, and is a consumer item. Any damage or dissatisfaction as a result of accidents or modifications are not covered by any warrantee and cannot be returned for repair or replacement. Please contact our distributors for free technical consultation and parts at discounted rates when you experience problems during operation or maintenance.





模型商品屬於操作技術且為消耗性商品，如經拆裝使用後，會造成不等情況零件損耗，任何使用情況所造成商品不良或不滿意，將無法於保固條件內更換新品或退貨，如遇有使用操作維修問題，本公司全省分公司將提供免費技術指導、特價零件供應服務。





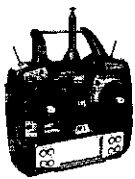





Fly only in safe areas, away from other people. Do not operate R/C aircraft within the vicinity of homes or crowds of people. R/C aircraft are prone to accidents, failures, and crashes due to a variety of reasons including, lack of maintenance, pilot error, and radio interference. Pilots are responsible for their actions and damage or injury occurring during the operation or as a result of R/C aircraft models.

遙控模型飛機、直昇機屬高危險性商品，飛行時務必遠離人群，人為組裝不當或機件損壞、電子控制設備不良，以及操控上的不熟悉、都有可能導致飛行失控損傷等意外，請飛行者務必注意飛行安全，並需了解自負任何意外之責任。

RADIO TRANSMITTER AND ELECTRONIC EQUIPMENT REQUIRED FOR ASSEMBLY 自備遙控及電子設備

			
Transmitter(6-channel, helicopter system) 發射機(六動直昇機模式遙控器)	Receiver(6-channel or more) 接收機(六動以上)	Gyro 鎖定式陀螺儀	9g Micro Servo3pcs 6g Micro servox1pc 動作控制9g伺服器x3 尾舵控制6g伺服器x1

ADDITIONAL TOOLS REQUIRED FOR ASSEMBLY 自備工具

							
Scissors 剪刀	Cutter Knife 刀子	Grease 潤滑油	CA 瞬間膠	Diagonal Cutting Pliers 斜口鉗	Needle Nose Pliers 尖嘴鉗	Hexagon Screw Driver 六角螺絲起子 3mm/2.5mm/2mm/1.5mm	Phillips Screw Driver 十字螺絲起子 φ 3.0/ φ 1.8mm



LOCATE AN APPROPRIATE LOCATION 遠離障礙物及人群

R/C helicopters fly at high speed, thus posing a certain degree of potential danger. Choose an appropriate flying site consisting of flat, smooth ground, a clear open field, or a large open room, such as gymnasium or warehouse without obstacles. Do not fly near buildings, high voltage cables, or trees to ensure the safety of yourself, others, and your model. Do not fly your model in inclement weather, such as rain, wind, snow or darkness.

直昇機飛行時具有一定的速度，相對的也潛在著一點危險性，場地的選擇也相對的重要。首先必須注意周遭有沒有人、高樓、建築物、高壓電線、樹木等等，避免操控的不當造成自己與他人財產的損壞。初次練習時，務必選擇在空曠場地並可適當搭配練習架練習飛行，這對飛行失誤所造成的損傷將會大幅的降低。請勿在下雨、打雷等惡劣天候下操作，以確保本身及機體的安全。

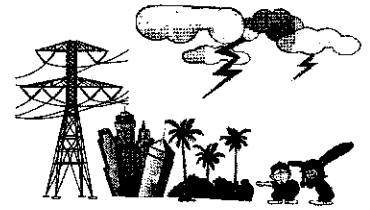

OBTAIN THE ASSISTANCE OF AN EXPERIENCED PILOT 避免獨自操控

Before turning on your model and transmitter, check to make sure no one else is operating on the same frequency. Frequency interference can cause your model, or other models to crash. The guidance provided by an experienced pilot will be invaluable for the assembly, tuning, trimming, and actual first flight. (Recommend you to practice with computer-based flight simulator.)

至飛行場飛行前，需確認是否有相同頻率的同好正進行飛行，因為開啓相同頻率的發射機將導致自己與他人立即干擾等意外危險。遙控飛機操控技巧在學習初期有著一定的難度，要盡量避免獨自操作飛行，需有經驗的人士在旁指導，才可以操控飛行。

(勤練電腦模擬器及老手指導是入門必要的選擇)



ALWAYS BE AWARE OF THE ROTATING BLADES 遠離運轉中零件

During the operation of the helicopter, the main rotor and tail rotor will be spinning at a high rate of speed. The blades are capable of inflicting serious bodily injury and damage to the environment. Be conscious of your actions, and careful to keep your face, eyes, hands, and loose clothing away from the blades. Always fly the model a safe distance from yourself and others, as well as surrounding objects. Never take your eyes off the model or leave it unattended while it is turned on. Immediately turn off the model and transmitter when you have landed the model.

當直昇機主旋翼與尾旋翼運轉時，切勿觸摸並遠離任何物件，以避免造成危險及損壞。



PREVENT MOISTURE 遠離潮濕環境

R/C models are composed of many precision electrical components. It is critical to keep the model and associated equipment away from moisture and other contaminants. The introduction or exposure to water or moisture in any form can cause the model to malfunction resulting in loss of use, or a crash. Do not operate or expose to rain or moisture.

直昇機內部也是由許多精密的電子零組件組成，所以必須絕對的防止潮濕或水氣，避免在浴室或雨天時使用，防止水氣進入機身內部而導致機件及電子零件故障而引發不可預期的意外！



KEEP AWAY FROM HEAT 遠離熱源

R/C models are made up various forms of plastic. Plastic is very susceptible to damage or deformation due to extreme heat and cold climate. Make sure not to store the model near any source of heat such as an oven, or heater. It is best to store the model indoors, in a climate-controlled, room temperature environment.

遙控飛機多半是以 PA 纖維或聚乙烯、電子商品為主要材質，因此要盡量遠離熱源、日曬，以避免因高溫而變形甚至熔毀損壞的可能。



PROPER OPERATION 勿不當使用本產品

Please use the replacement of parts on the manual to ensure the safety of instructors. This product is for R/C model, so do not use for other purpose.

請勿自行改造加工，任何的升級改裝或維修，請使用亞拓產品目錄中的零件，以確保結構的安全。請確認於產品限界內操作，請勿過載使用，並勿用於安全、法令外其它非法用途。

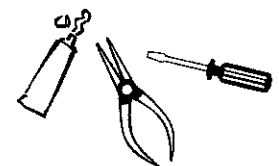

SAFE OPERATION 安全操作

Operate this unit within your ability. Do not fly under tired condition and improper operation may cause in danger.





請於自己能力內及需要一定技術範圍內操作這台直昇機，過於疲勞、精神不佳或不當操作，意外發生風險將可能會提高。

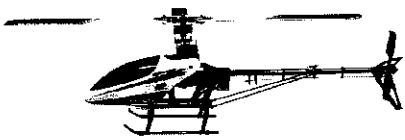

CAREFULLY INSPECT BEFORE REAL FLIGHT 實機飛行前請嚴格執行飛行前檢查義務

- ☆ Before flying, please check to make sure no one else is operating on the same frequency for the safety.
 - ☆ Before flight, please check if the power of transmitter and helicopter are enough for the flight.
 - ☆ Before turn on the transmitter, please check if the throttle stick is in the lowest position. IDLE switch is OFF.
 - ☆ When turn off the unit, please follow the power on/off procedure. Power ON- Please turn on the transmitter first, and then turn on helicopter power. Power OFF- Please turn off the helicopter power first and then turn off the transmitter. Improper procedure may cause out of control, so please to have this correct habit.
 - ☆ Before operation, check every movement is smooth and directions are correct. Carefully inspect servos for interference and broken gear.
 - ☆ Check for missing or loose screws and nuts. See if there is any cracked and incomplete assembly of parts. Carefully check main rotor blades and rotor holders. Broken and premature failures of parts possibly cause resulting in a dangerous situation.
 - ☆ Check all ball links to avoid excess play and replace as needed. Failure to do so will result in poor flight stability.
 - ☆ Check the battery and power plug are fastened. Vibration and violent flight may cause the plug loose and result out of control.
 - ☆ Check for the tension of tail drive belt.
- ★ 每次飛行前應先確認所使用的頻率是否會干擾他人，以確保你自身與他人的安全。
- ★ 每次飛行前確定您發射機與直昇機電池的電量是在足夠飛行的狀態。
- ★ 開機前確認油門搖桿是否位於最低點，熄火降落開關，定速開關 (IDLE) 是否於關閉位置。
- ★ 關機時必須遵守電源開關機的程序，開機時應先開啓發射機後，再開啓直昇機電源；關機時應先關閉直昇機電源後，再關閉發射機電源。不正確的開關機程序可能會造成失控的現象，影響自身與他人的安全，請養成正確的習慣。
- ★ 開機請先確定直昇機各個動作是否順暢，及方向是否正確，並檢查伺服器的動作是否有干涉或崩齒的情形，使用故障的伺服器將導致不可預期的危險。
- ★ 飛行前確認沒有缺少或鬆脫的螺絲與螺帽，確認沒有組裝不完整或損毀的零件，仔細檢查主旋翼是否有損壞，特別是接近主旋翼夾座的部位。損壞或組裝不完整的零件不僅影響飛行，更會造成不可預期的危險。注意：對損耗、有裂痕零件更新及定期保養檢查重要性。
- ★ 檢查所有的連桿頭是否有鬆脫的情形，過鬆的連桿頭應先更新，否則將造成直昇機無法操控的危險。
- ★ 確認電池及電源接頭是否固定牢靠，飛行中的震動或激烈的飛行，可能造成接頭鬆脫而造成失控的危險。
- ★ 確定尾傳動皮帶的鬆緊度。

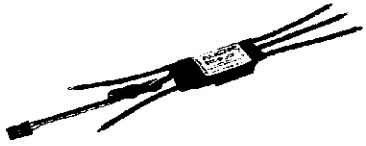
Standard Equipment 標準配備

 <p>T-REX 450SE V2 Kit x1 T-REX450SE V2空機版x1</p>	 <p>325 Carbon Rotor Blade x1 325碳纖主旋翼x1</p>	 <p>RCM-BL35X 35A Brushless ESC x1 RCM-BL35X 35安培無刷調速器x1</p>
 <p>430XL 3700KV Brushless motor x1 430XL 3700KV無刷馬達x1</p>	 <p>3S1P 11.1V 2100mAh/22Cx1</p>	

When you see the marks as below, please use glue or grease to ensure flying safety.

標有下符號之組裝步驟，請配合上膠或上油，以確保使用之可靠度。



- CA:** Apply CA Glue to fix.
 - R48:** Apply Anaerobics Retainer to fix.
 - T43:** Apply Thread Lock to fix.
 - OIL:** Add Grease.
- CA: 使用瞬間膠固定
R48: 使用金屬管狀固定缺氧膠固定
T43: 使用螺絲缺氧膠
OIL: 添加潤滑油

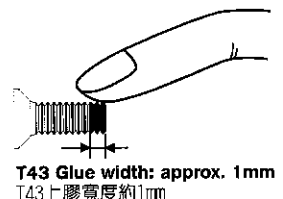

R48 metal tubular adhesive (eg. Bearings). T43 thread lock, apply a small amount on screws or metal parts and wipe surplus off. When disassembling, recommend to heat the metal joint about 15 Seconds. (NOTE: Keep plastic parts away from heat.) R48 為強力金屬管狀 (如軸承) 接著劑，T43為螺絲膠，膠合螺絲或金屬內外徑請務必少量使用，必要時請用手去除多餘膠量，欲拆卸時可於金屬接合部位熱烤約15秒。(注意：塑膠件避免接近熱源)

When assembling ball links, make sure the "A" character faces outside.
各項塑膠製連桿頭扣接時，A字請朝外。

HH

★ Insert the main rotor housing diagonally into the flybar seesaw holder.

★ 請將主旋翼固定座以對角方式裝入平衡桿固定座。

Make sure the mount can slide up and down smoothly and freely
固定座上下保持搖動順暢。

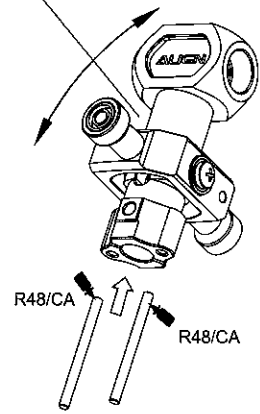

Metal main rotor housing
金屬主旋翼固定座
17X37.5X11mm

Pin
定位插銷
φ 1.5X18.7mm

Metal flybar seesaw holder
金屬平衡桿固定座
36X14.5X7mm

Collar screw
軸套螺絲
M2X8mm

Washer
華司
φ 2X φ 3.6X0.2mm

Collar screw
軸套螺絲
M2X6.5mm

Bearing MR52ZZ
軸承MR52ZZ
φ 2X φ 5X2.5mm

Cross screw
皿頭十字螺絲
M2X6.5mm

Already assembled
已裝入

Bearing MR52ZZ
軸承MR52ZZ
φ 2X φ 5X2.5mm

Make sure the linkage balls are tightly secured.
務必將每顆金屬球頭鎖緊上緊螺絲，不可鬆動。

Bearing FMR52ZZ
軸承FMR52ZZ
φ 2X φ 5X φ 6X2.3mm

Already assembled
已裝入

Bearing MR52ZZ
軸承MR52ZZ
φ 2X φ 5X2.5mm

Washer
華司
φ 2X φ 3.6X0.2mm

Stainless steel linkage ball
不銹鋼球頭
φ 4.75

SF mixing arm
SF控制搖臂
31.45X5.5mm

Washer
華司
φ 2X φ 3.6X0.5mm

Collar screw
軸套螺絲
M2X8mm

Make sure the arms move smoothly and freely.
調整鎖緊時需讓SF搖臂轉動順暢

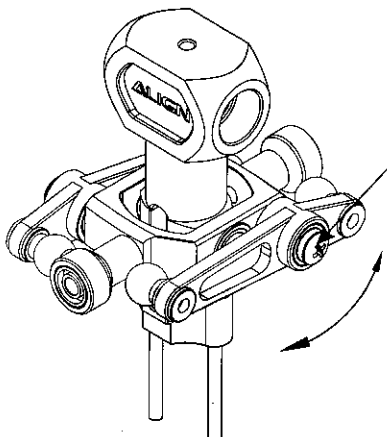

HH

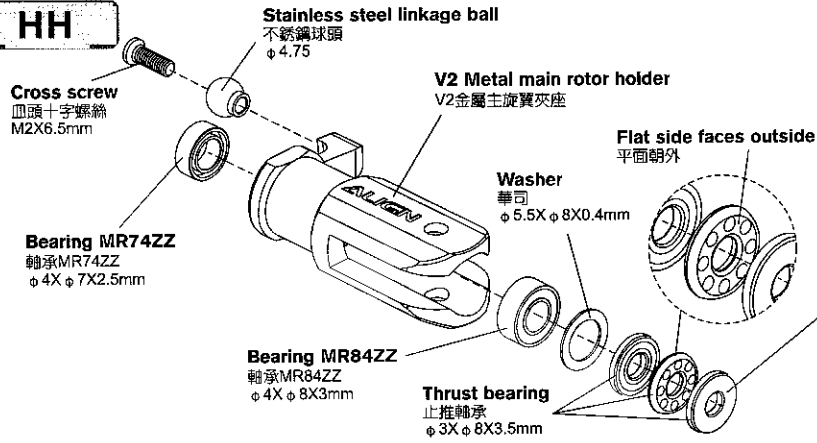

CAUTION 注意

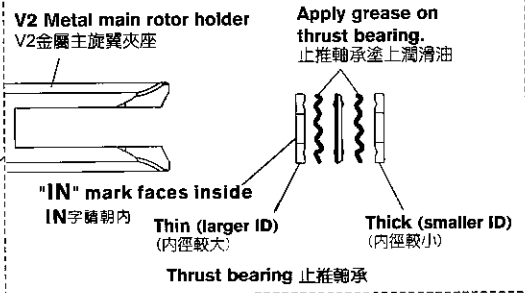

HH

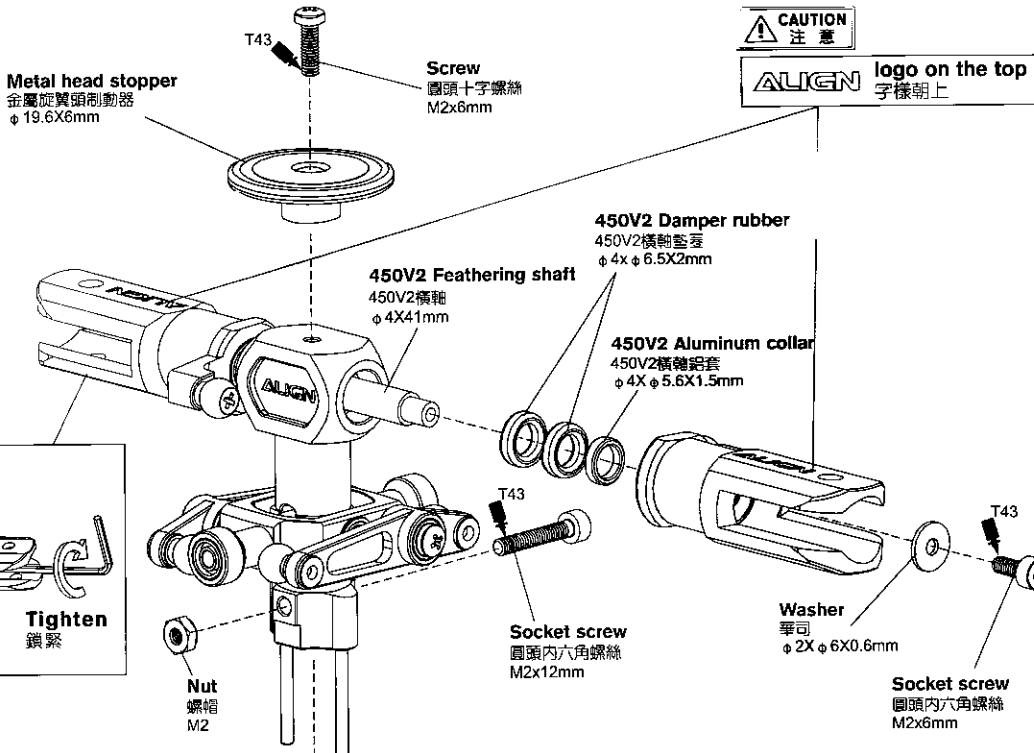

CAUTION 注意

ALIGN logo on the top 字樣朝上

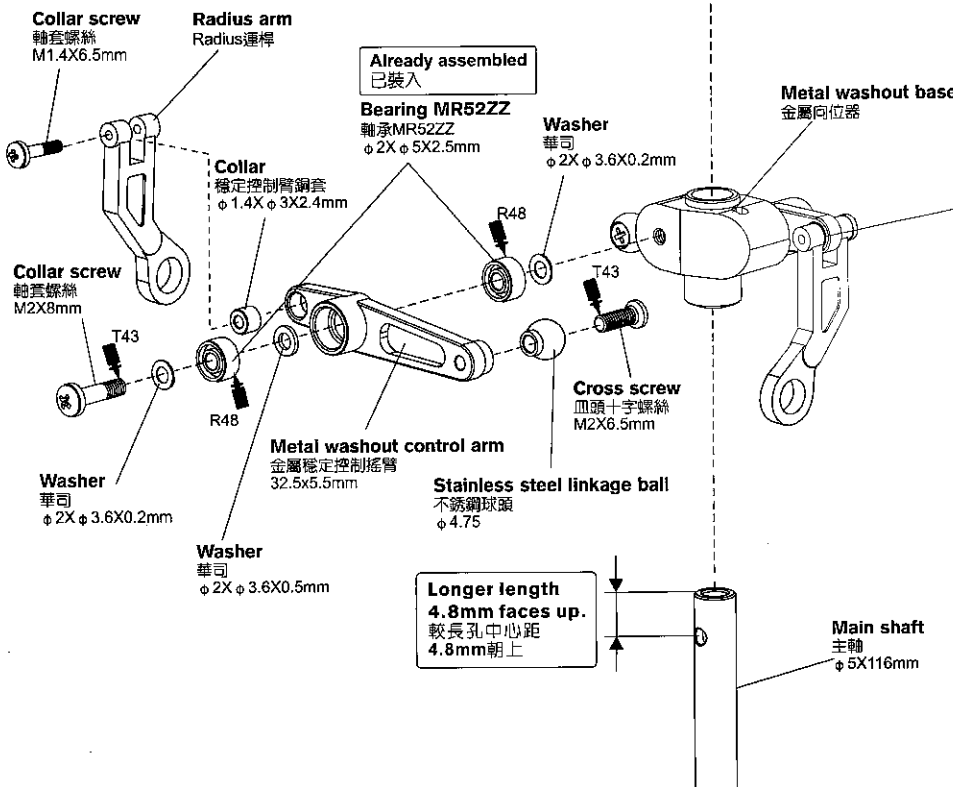
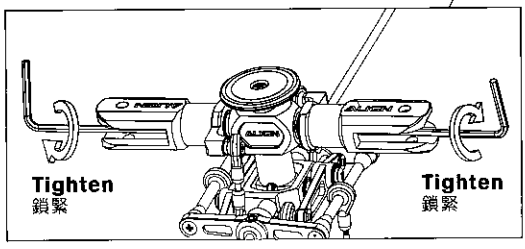

Make sure the linkage balls are tightly secured. 鎖緊時需轉動順暢

Longer length 4.8mm faces up. 較長孔中心距 4.8mm朝上

HH4

Metal main rotor head assembly 金屬主旋翼組

Already assembled by factory,
please note to check again.
已組裝完成，飛行前請務必自行再確認
檢查各螺絲是否鬆動裝緊。

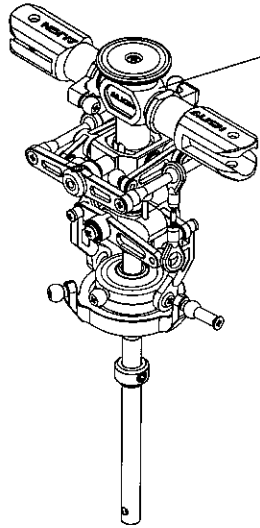

Cross screw
皿頭十字螺絲
M2x5mm

Flybar rod
平衡翼桿
φ 1.97X220mm

20.75mm 18.25mm

Flybar control rod
平衡翼控制球桿
φ 4.3X39mm

Set screw
止洩螺絲
M3x3mm

Assemble linkage rod(B) before
assembling flybar control set.
組裝平衡翼控制組前將B連桿裝入。

Approx. 23.5mm
約23.5mm

X2

Cross screw
皿頭十字螺絲
M2x5mm

Metal flybar control arm
金屬平衡翼T型控制臂
38.3X4.5mm

CCPM Swashplate
CCPM十字盤組
φ 26X11.5mm

Lock ring
主軸固定套
φ 5X8mm

Set screw
止洩螺絲
M3x3mm

HH4

Set screw
止洩螺絲
M3x3mm

For more stable flight, install the flybar weights as shown.
For more Acrobatic flight, the flybar weights are not required.
一般飛行時可於副翼加重，藉以提高飛行穩定性。
特技飛行時則不需加重，可展現3D動作的靈活性。

Flybar paddle
平衡翼

Flybar weight
平衡翼重錘
φ 7.5X8mm

R48

84.4mm

84.4mm

Make sure both sides are equal in length
平衡桿須調整等邊長度約77mm

Approx. 77mm
約77mm

Rotate in a clockwise direction.
順時針旋轉

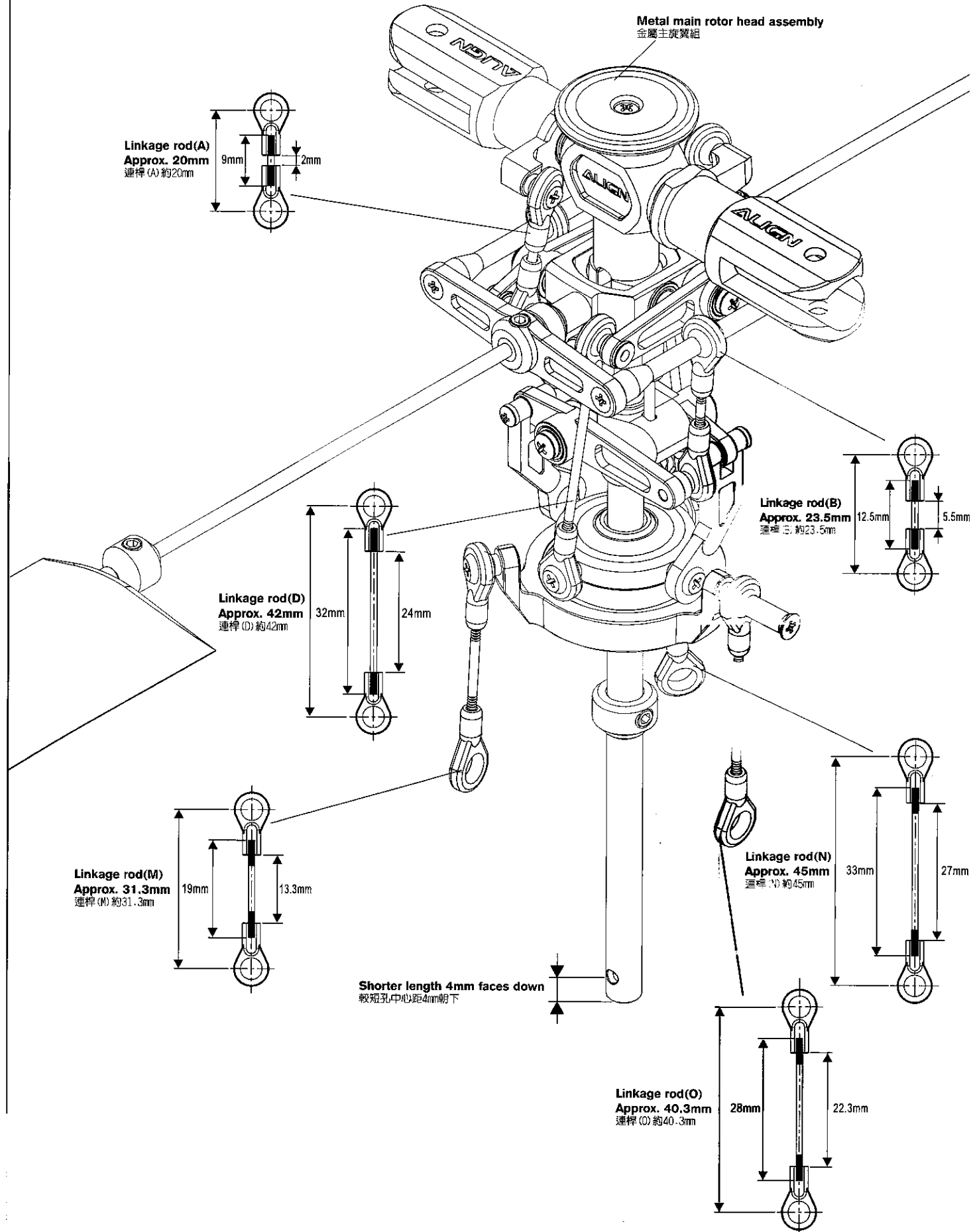

HB2

The screws must be firmly tightened, but not over tightened, or they will strip and become loose. Apply screwlok where screws are tightened into metal objects.

組裝側板時所使用的螺絲可視需要塗用螺絲防鬆膠，要特別注意的是：螺絲必須確實鎖緊，但是要小心不能過度鎖緊，以避免發生滑牙或斷裂現象。

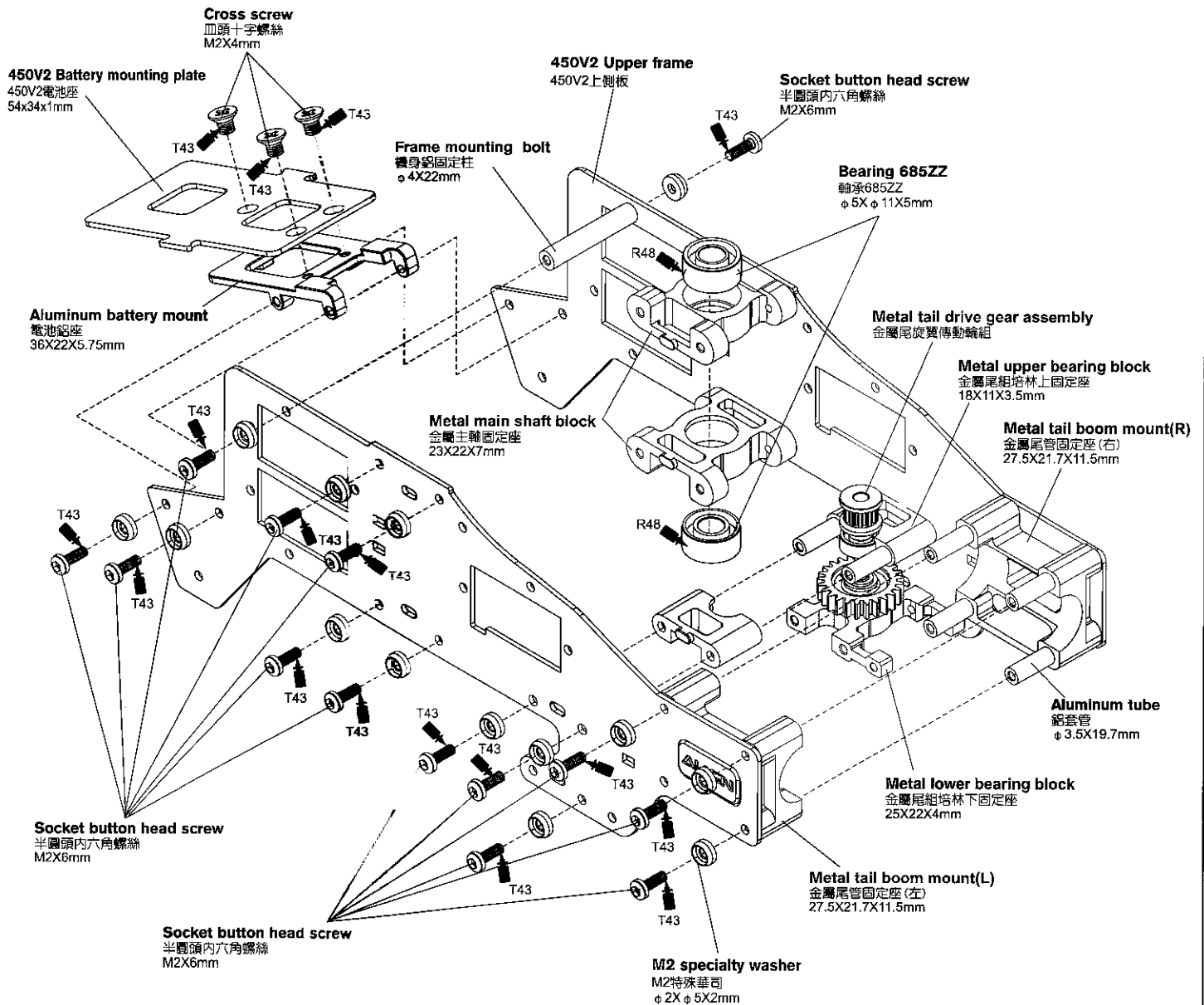

Make sure the frames are tightly secured without gaps.
組裝後請檢查左右主體間不可有間隙，確保被鎖固不鬆動。

Please check if the main shaft rotates smooth after assembling the main frames.
機體組裝後請注意主軸需滑順

Already assembled by factory, please note to check again.
已組裝完成，飛行前請務必自行再確認檢查各螺絲是否點膠鎖緊。

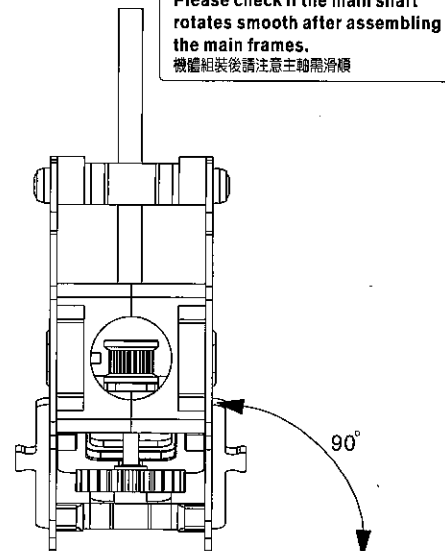

Please note vertical angle when assembling.
(組裝主體側板須注意直角度)

450V2 Lower frame
450V2下側板

Bottom plate
底板
172.5X39X5mm

M2 specialty washer
M2特殊華司
φ2X φ5X2mm

Socket button head self tapping screw
半圓頭內六角鐵板螺絲
T2X6mm

Already assembled by factory,
please note to check again.
已組裝完成，飛行前請務必自行再確
認檢查各螺絲是否點膠鎖緊。

Recommend sanding the marked position as below
illustration with a waterproof abrasive paper (#600-800)
to avoid the wires of electric parts to be cut.
建議於下圈色塊標示處，使用#600-800水砂紙打磨，可防止電子
設備電線被割破。

waterproof abrasive paper
水砂紙

Frame mounting bolt
機身鋁固定柱
φ4X22mm

Aluminum link
上下側板接合鉗柱
φ2X φ5X7.5mm

Metal motor mount
金屬馬達固定座
36.4X39mm

Main frame assembly
機身鉸

Socket button head screw
半圓頭內六角螺絲
M2X14mm

Socket button head screw
半圓頭內六角螺絲
M2X14mm

Socket button head screw
半圓頭內六角螺絲
M2X6mm

M2 specialty washer
M2特殊華司
φ2X φ5X2mm

Socket button head screw
半圓頭內六角螺絲
M2X14mm

HB2

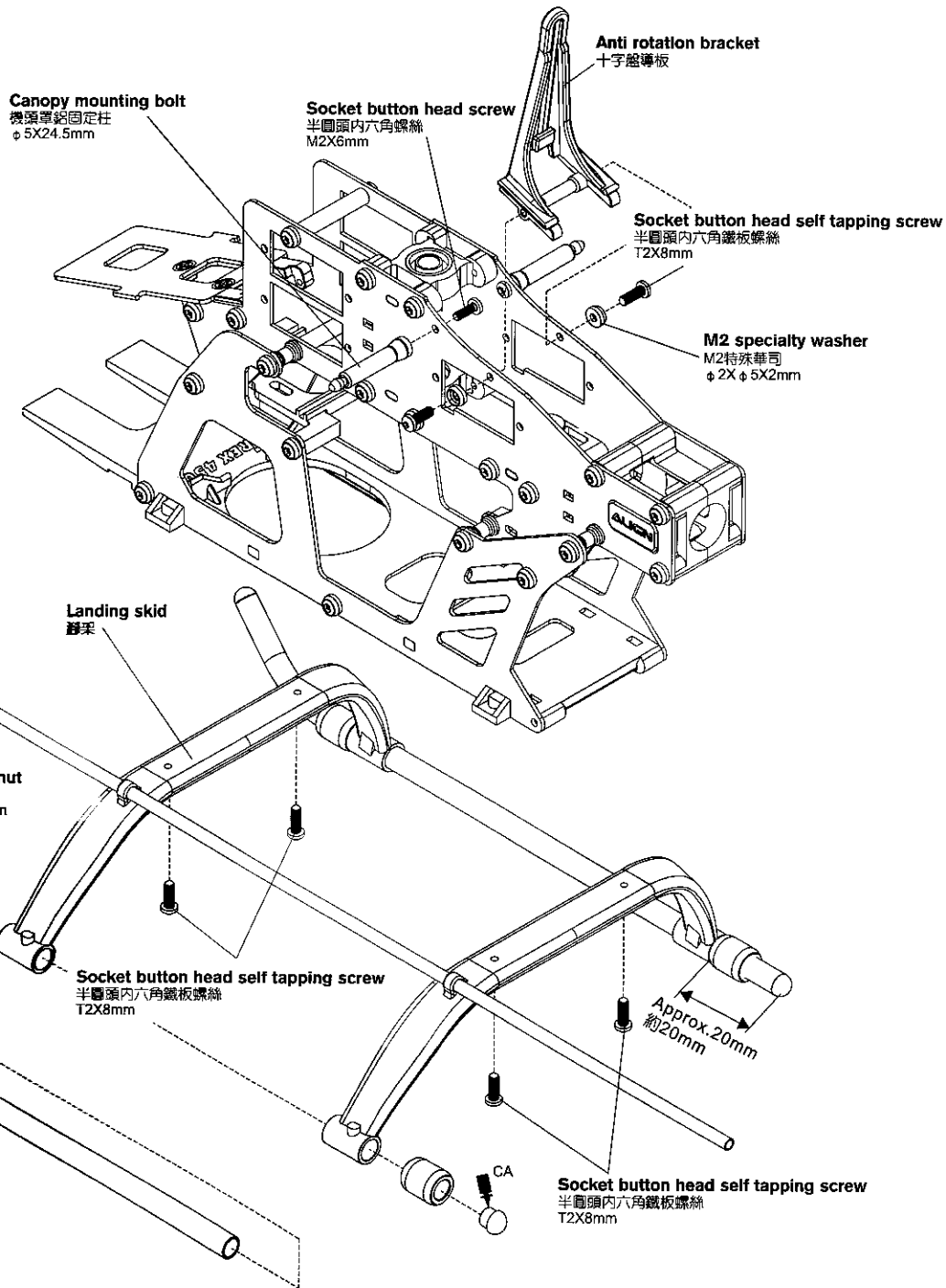

HB6

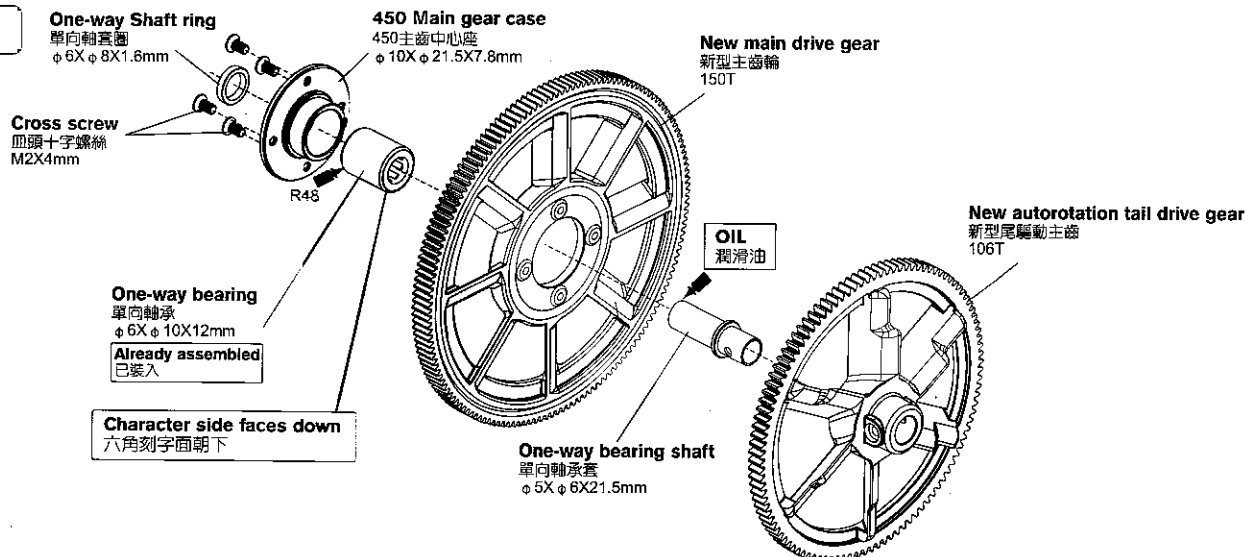

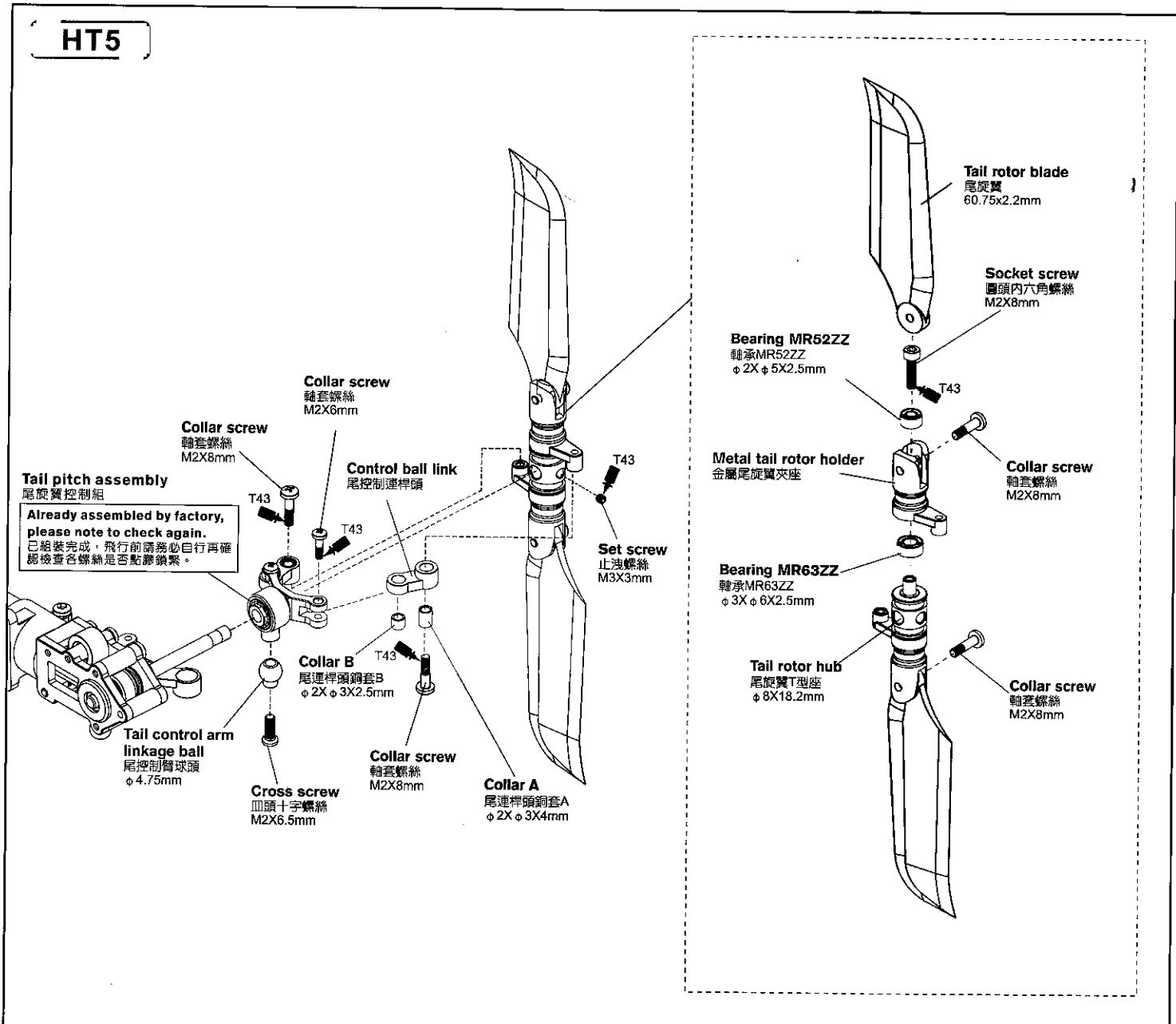
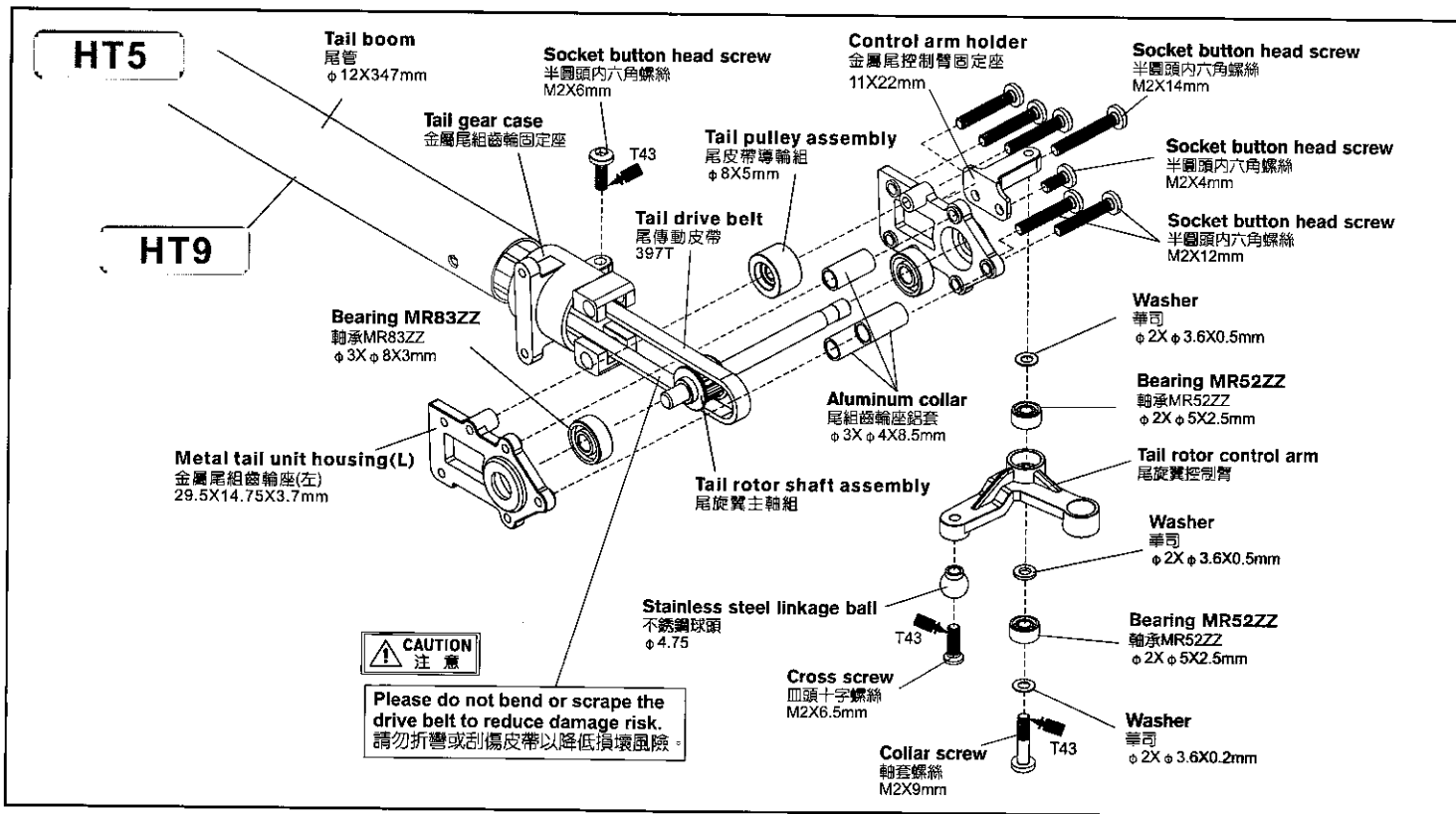

HT3

CAUTION
注意

Tail boom brace end
尾管支撐架接頭

Tail boom brace
尾管支撐架
φ3X205mm

Apply some glue on tail boom brace ends to avoid vibration. When gluing, note the two ends must be parallel to each other, or they can't be fixed flat.
尾管支撐架接頭上膠，如果不上膠，可能導致震動。上膠時請注意前後接頭必須平行，否則會有無法平貼鎖附的情形。

HT9

Please do not tighten the screws before assembling tail boom.
裝尾管前螺絲請勿上緊

CAUTION
注意

Aim the opening of tail boom at the convex of the tail boom mount and insert.
瞄準尾管上的凹槽和尾座凸出，並插入。

Please insert the opening of tail boom into the convex.
尾管缺口方向裝入時，請導入導尾管座卡槽內。

Socket button head screw
半圓頭六角螺絲
M2X6mm

HT9

Metal tail servo mount
金屬尾伺服器座

Socket button head self tapping screw
半圓頭內六角鐵板螺絲
T2X8mm

3K Carbon horizontal stabilizer
3K碳纖維水平翼

M2 specialty washer
M2特殊華司
φ2Xφ5X2mm

Washer
華司
φ2Xφ6X0.6mm

Washer
華司
φ2Xφ6X0.6mm

Tail boom brace end
尾管支撐架接頭

M2 specialty washer
M2特殊華司
φ2Xφ5X2mm

Collar screw
軸套螺絲
M2X9mm

Tail boom brace
尾管支撐架
φ3X205mm

HT9

Tail control guide
尾控制桿固定環

Stabilizer mount
水平翼固定座

M2 specialty washer
M2特殊華司
φ2Xφ5X2mm

Socket button head self tapping screw
半圓頭內六角鐵板螺絲
T2X8mm

Tail rotor assembly
尾翼組

After assembling, recommend cutting the bottom part.
建議組裝後可將水平翼固定座下方切除。

M2 specialty washer
M2特殊華司
φ2Xφ5X2mm

T43

T43

Socket button head screw
半圓頭內六角螺絲
M2X6mm

450V2 Carbon vertical stabilizer
450V2碳纖維垂直翼

CAUTION
注意

Drive belt illustration 尾傳動皮帶裝配圖示

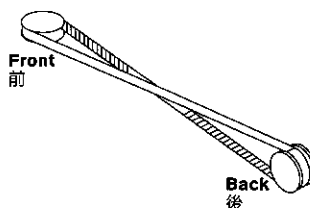

1. Check to rotate the belt 90 degrees when assembling.
2. Belt tension: Recommend to lightly tighten the drive belt after assembling tail boom to avoid vibration, belt friction and rotation slip.

1. 組裝時確認皮帶順轉90°。
2. 皮帶緊度：建議尾管組裝後皮帶請稍微拉緊，避免震動皮帶摩擦或轉動打滑。

HH3

325 Carbon rotor blade
325 碳纖主旋翼
325mm

Socket screw
圓頭內六角螺絲
M3X14mm

Nut
螺帽
M3

Socket screw
圓頭內六角螺絲
M2.6X6mm

For motor fixing
馬達固定螺絲

Washer
華司
φ 2.6X φ 6mm

Standard Belt Tension Guide:
Visualize a straight line through the center of the main drive gear. You should be able to apply light tension to the belt with your finger until it reaches a point 3/4 of the way to the opposite edge of the main gear, or 1/4 of the way past the virtual center of the main gear. Refer to photo.

皮帶緊度標準：
皮帶輕壓單邊可達傳動輪中心線以下3/4為標準。
(較鬆皮帶調整將對動力提升有幫助)

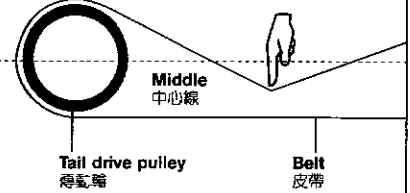

Set the motor pinion gear to main drive gear mesh to approximately 0.1mm to avoid excess power consumption or motor burnt due to overload.
馬達前後可移動以保持兩齒輪咬合處約有0.1mm間隙。過緊咬合將造成動力損失或馬達高阻力的過載，嚴重可能導致馬達燒毀。

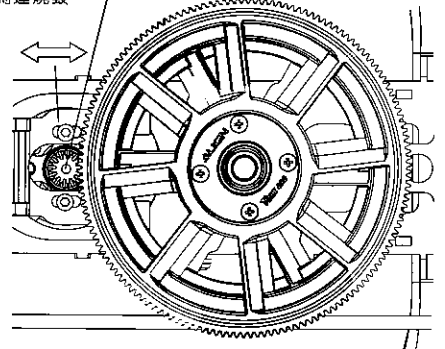

Motor pinion gear 12T for hovering, general, 3D flights.
Motor pinion gear 13T for hard 3D flight.
12T馬達主齒 一般飛行停懸、空中、3D飛行模式
13T馬達主齒 暴力3D飛行模式

Set screw
止洩螺絲
M3X3mm

T43

Motor
馬達
3700KV

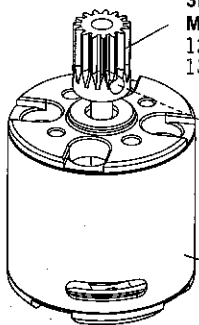

1. Please prepare three micro servos (9g) for CCPM swashplate control and one quick speed (0.12sec/within 60 degrees) micro servo (6~9g) for tail rudder control. First remove the servo horn from the three servos for swashplate.

請準備3個型號相同的小型伺服器(9g)作為CCPM十字盤控制用, 1個速度較快(0.12sec/60度以內)的小型伺服器(6~9g), 作為尾舵控制用。首先將十字盤控制用伺服器的舵片拆下。

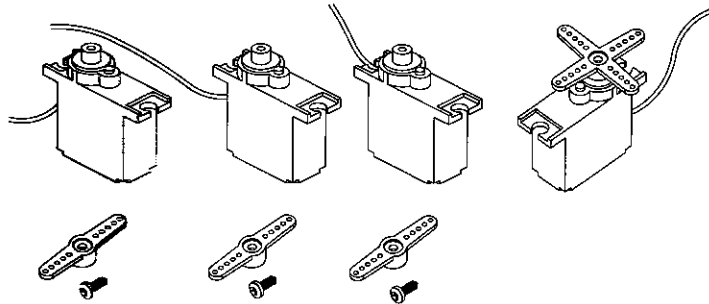

2. Use a 1.5mm Hex wrench, remove the aluminum bolts from the main frames to install the servos. After installation, note to reinstall the aluminum bolts.

使用1.5mm的六角扳手將固定於機身的鋁固定柱暫時拆下, 以便安裝伺服器, 安裝完成後要記得將固定柱裝回。

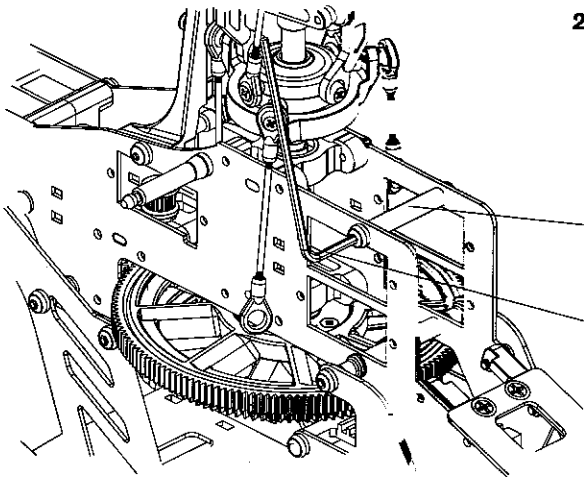

Frame aluminum bolt
機身鋁固定柱

1.5mm Hex wrench
1.5mm六角扳手

3. First install the servo inside the lower mount. Note the output shaft must be oriented toward the rear of the helicopter.

如圖示, 先將伺服器安裝於下方的固定座, 注意伺服器齒輪軸需偏向直昇機の後方。

Servo
伺服器

Plastic nut
塑膠螺帽

4. Use T2x8 Socket button head self-tapping screw and nuts to fix the servo from two sides.

以零件包所附的T2x8半圓頭內六角鐵板螺絲與塑膠螺帽, 將伺服器的兩側鎖附固定。

Socket button head self tapping screw
半圓頭內六角鐵板螺絲
T2X8mm

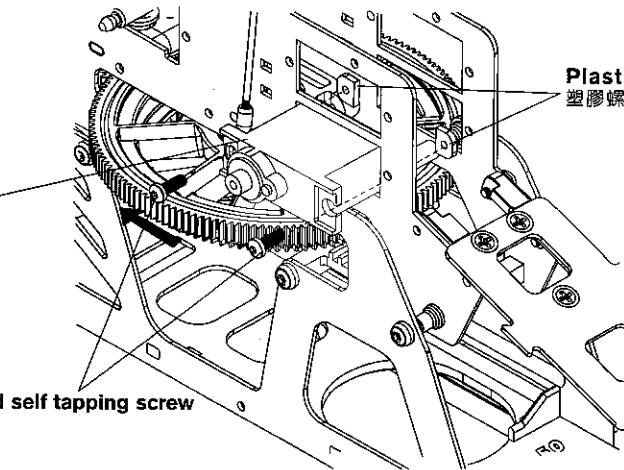

5. Next, install the second servo inside the upper mount. Note the output shaft must be oriented toward the rear of the helicopter. Then use the screws to fix.

接下來, 將第二顆伺服器安裝於上方的固定座, 伺服器齒輪軸須偏向直昇機の後方, 再以螺絲將伺服器裝附固定。

Plastic nut
塑膠螺帽

Servo
伺服器

Socket button head self tapping screw
半圓頭內六角鐵板螺絲
T2X8mm

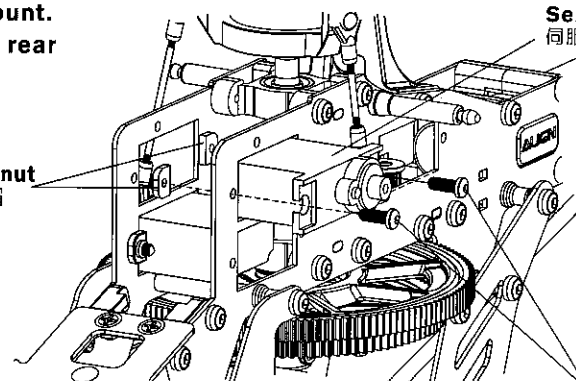

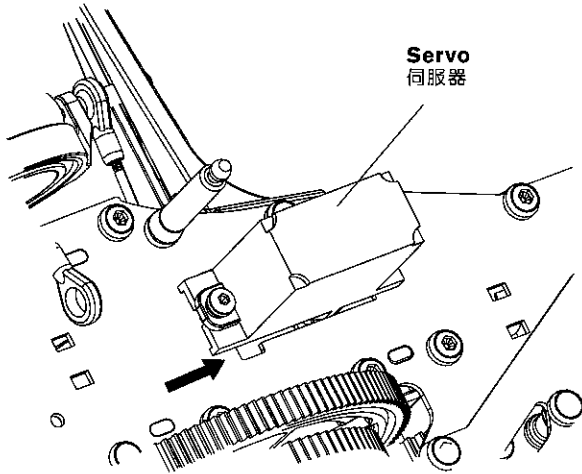

6. See the picture, install the third servo outside the rear mount of the main frame (L) or (R). The servo is installed outside of the frame and the output shaft must be oriented toward the rear of the helicopter, set the signal wire in the retained space to avoid any scrape. Then use the screws and nuts to fix.

如圖示, 第三顆伺服器安裝在左側板(或右側板)後方的固定座, 伺服器本體外露機身, 伺服器齒輪軸偏向直昇機後方, 訊號線可置於預留的小孔避免刮傷, 再以螺絲及螺帽將伺服器鎖附固定。

7. Set the signal wire next to the main frame inside and use a strap to secure it for avoiding scraping the wire and interfering the flight. Finally, set the servo neutral and then reinstall the servo horn.

將伺服器的訊號線貼近側板內側, 並以束線帶加以固定, 以免訊號線刮傷或干涉直昇機動作。最後待伺服器中立點調整後, 再將拆下的伺服舵片裝回。

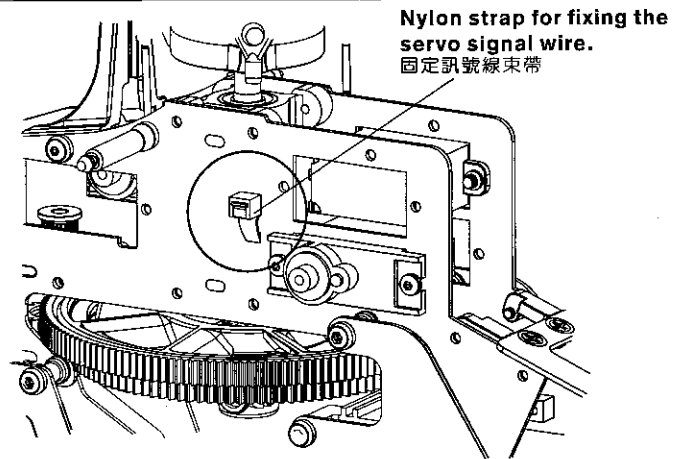

8. Install the tail rudder servo on the tail servo mount. Set the servo horn and linkage rod at right angle (90 degrees).

依圖示的方向將尾舵伺服器鎖附於固定座上, 注意舵片與連桿須呈90度。

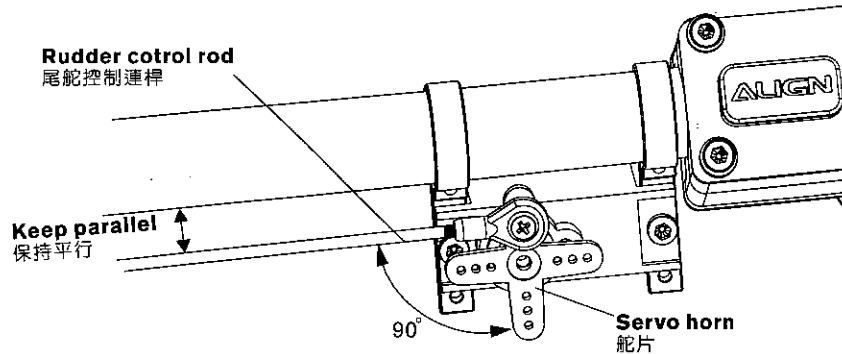

9. Install the rudder control rod to the linkage ball of tail rotor control arm.

尾舵控制連桿的另一端則壓入尾旋翼控制臂的球頭上。

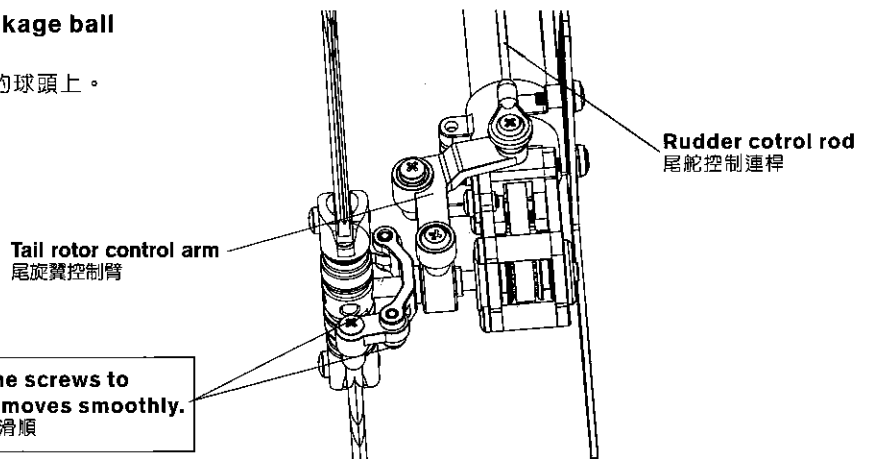

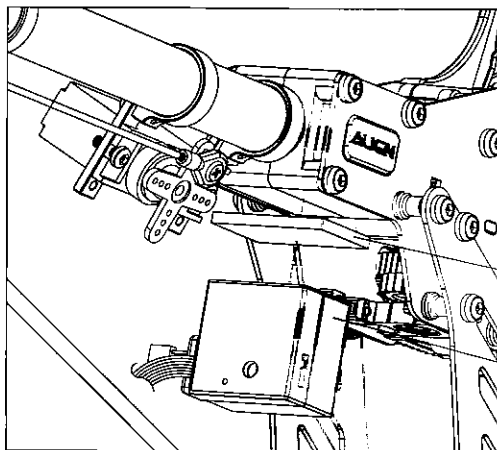

Adhesive foam
泡棉雙面膠

Gyro
陀螺儀

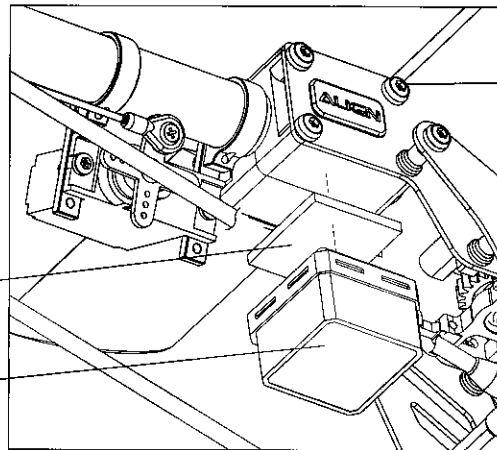

First clean the mounting surface and the bottom surface of the gyro. Then use a adhesive foam to secure the gyro on the top of the tail boom mount.

先將陀螺儀與尾管固定座的貼合面擦拭乾淨,再使用泡棉雙面膠確實將陀螺儀固定。

Battery mounting and fixing 電池安裝與固定

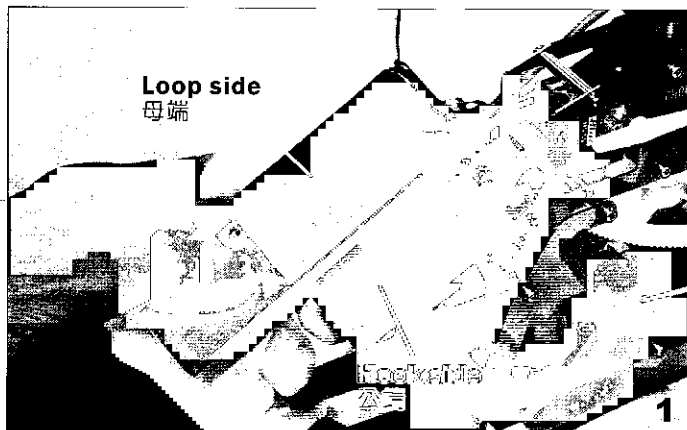

Use Hook and Loop Tape, tape the Hook side (hooked) on the battery mounting plate and the Loop side (fuzzy) on the battery (see illustration) to fix the battery and avoid any slip.

以附贈的魔術沾膠帶,將公端的魔術沾(勾狀)粘貼於電池座上,母端的魔術沾(纖毛狀)黏貼於電池上(如照片所示),可有效的固定電池,避免滑動。

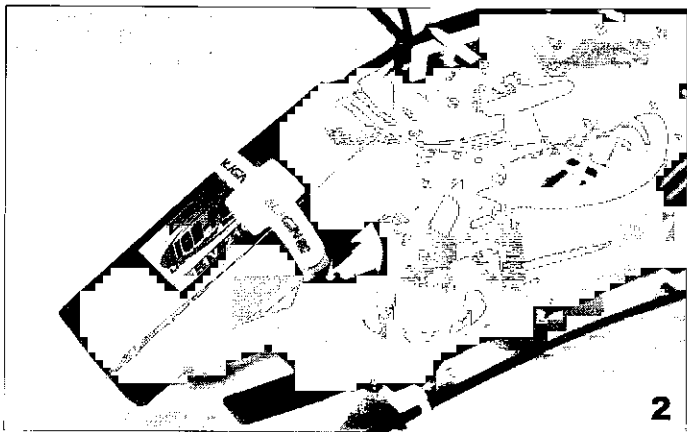

Adjust the battery position forward or backward to set the center of gravity until the model holds a level position when levelly lift up the main rotor blades to make the model in the air. After checking the center of gravity, use a hook and loop fastening tape to secure the battery.

移動電池的前後來調整直昇機的重心,直到水平提取主旋翼使機身懸空時,機身也呈水平狀態,重心確認後,以所附的魔術帶將電池束緊固定。

Motor and ESC connection 馬達與調速器的連接

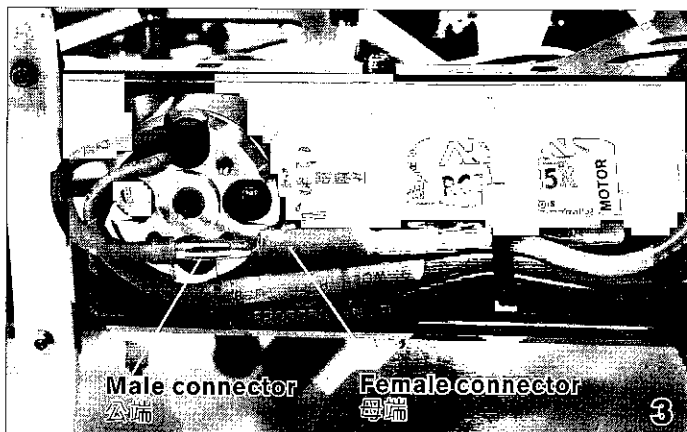

Follow the illustration to install the ESC and use a strap to secure it. Please solder the three wires of motor by 3.0mm male gilt connectors; solder the wires of ESC by the female gilt connectors. After soldering, put on the heat shrink tubes according to the colors and heat the tubes to shrink. Finally, insert the gilt connectors of motor and ESC according to the colors.

調速器可依照左圖建議的位置安裝,並以束線帶固定,馬達端的三條出口線請以公端3.0mm 鍍金接頭焊接,調速器則焊上母端,完成後依相同的顏色套上熱縮套管加熱收縮,最後依相同的顏色將馬達與調速器的鍍金接頭插入。

7. EQUIPMENT ILLUSTRATION 設備建議配置圖示

ALIGN

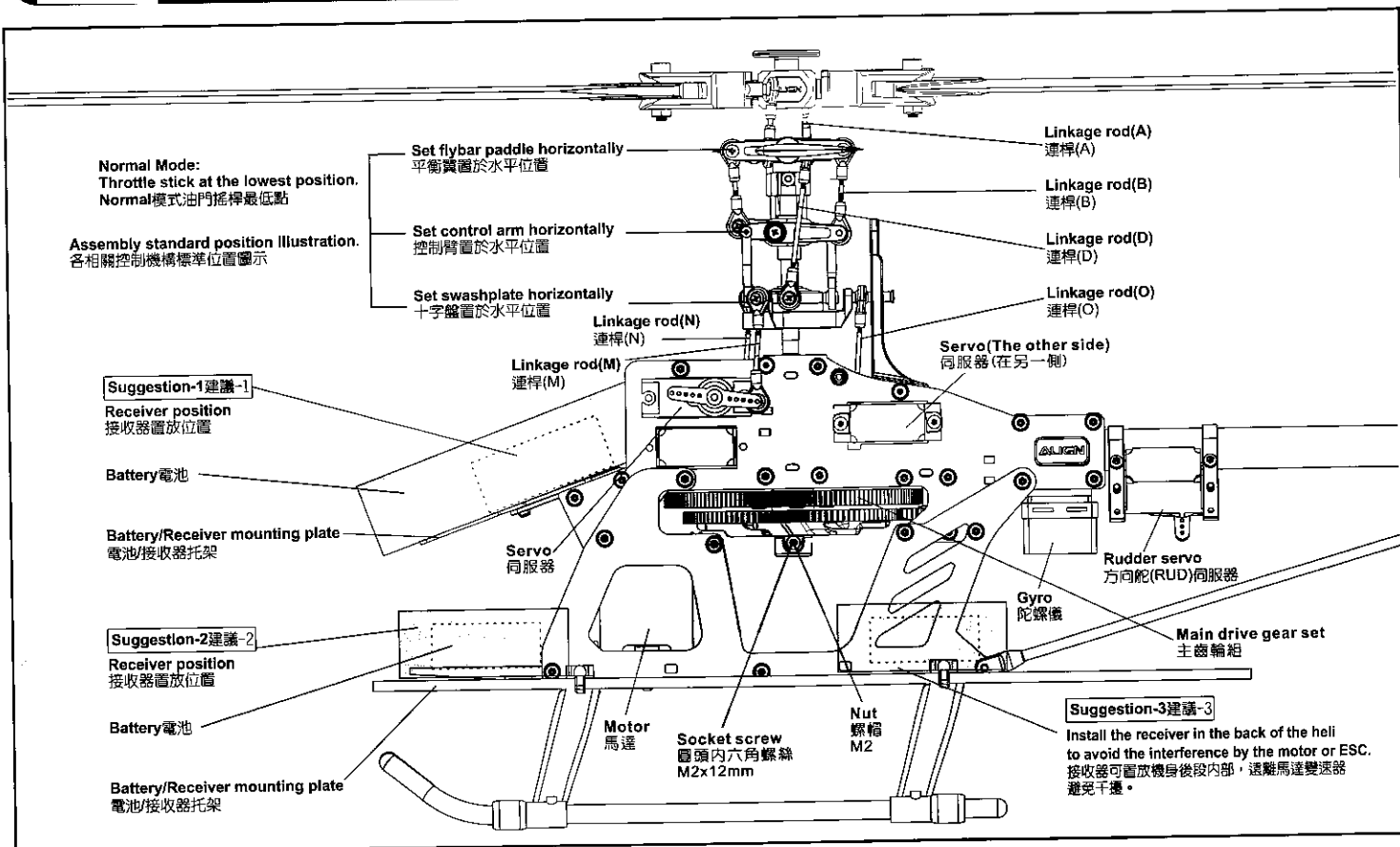

8. MAIN ROTOR ADJUSTMENTS 主旋翼平衡與雙槳校正

ALIGN

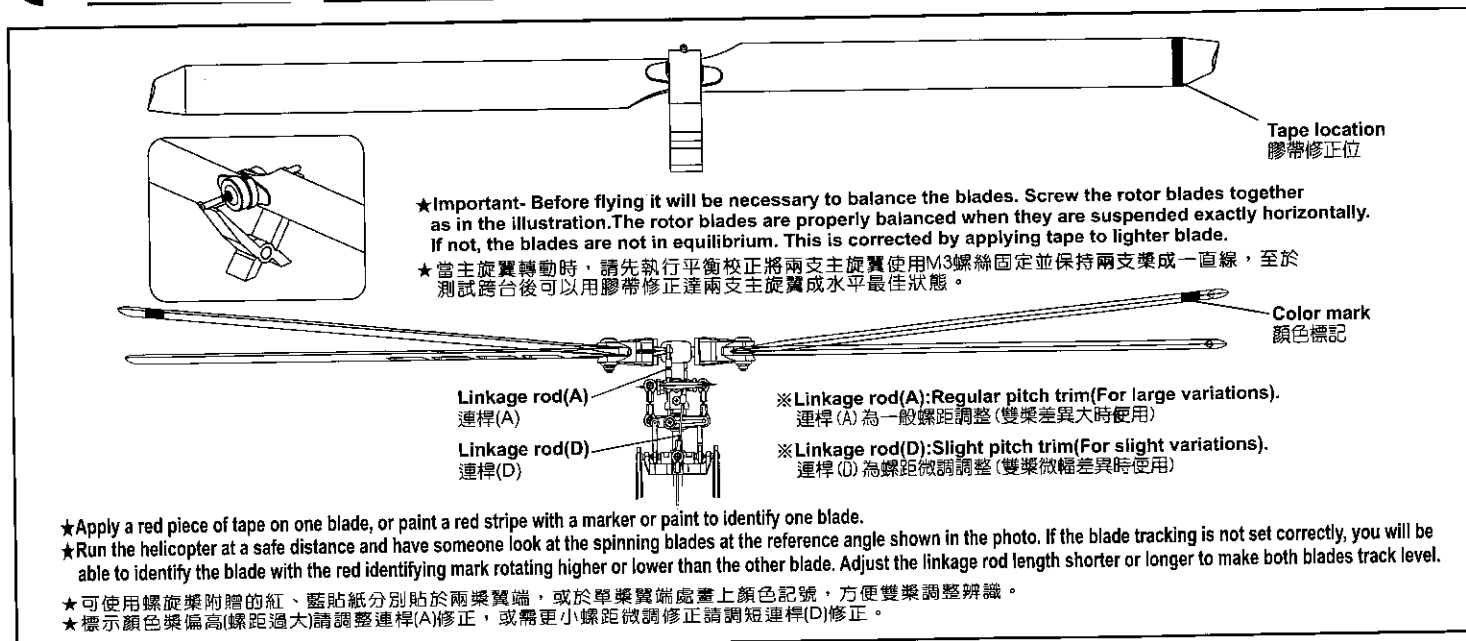

- ★ Apply a red piece of tape on one blade, or paint a red stripe with a marker or paint to identify one blade.
- ★ Run the helicopter at a safe distance and have someone look at the spinning blades at the reference angle shown in the photo. If the blade tracking is not set correctly, you will be able to identify the blade with the red identifying mark rotating higher or lower than the other blade. Adjust the linkage rod length shorter or longer to make both blades track level.
- ★ 可使用螺旋槳附贈的紅、藍貼紙分別貼於兩槳翼端，或於單槳翼端處畫上顏色記號，方便雙槳調整辨識。
- ★ 標示顏色槳偏高(螺距過大)請調整連桿(A)修正，或需更小螺距微調修正請調短連桿(D)修正。

9. TROUBLESHOOTING THE POWER SYSTEM 動力異常檢查

ALIGN

Please check the battery when the power or speed gets abnormally slow:

1. Check the battery is the correct specification for the helicopter and is fully charged.
2. Check if the pitch setting is too high. (If the pitch setting is too high, it will affect the power efficiency and flight time.)
3. Check the tightness of the main rotor blades. Blades should be tightened so that they do not move freely, but can be moved by applying slight pressure by hand.
4. Check for vibration on the main and tail rotors (vibration can be caused by main shaft/feathering shaft wear, damage, or loosens, check all linkages and bearings for excess play or wear).
5. Check for interference caused by improper gear mesh or belt tension.

您的標準動力配置如有發現動力效能與速度明顯降低時，可注意下列幾點因素：

1. 電池規格效能與電力是否足夠!
2. Pitch是否過大!(過大pitch設定，將明顯影響動力效能與飛行時間)
3. 主旋翼是否有雙槳!
4. 主旋翼與尾旋翼是否明顯震動!(主軸、主/橫軸變型與鬆動所產生震動※必要時請更新或上膠固定)
5. 各傳動齒或傳動軸是否太緊的干涉!(特別注意!馬達主齒與主齒輪需有適當間隙)
6. 皮帶是否太鬆而震動或太緊的干涉!

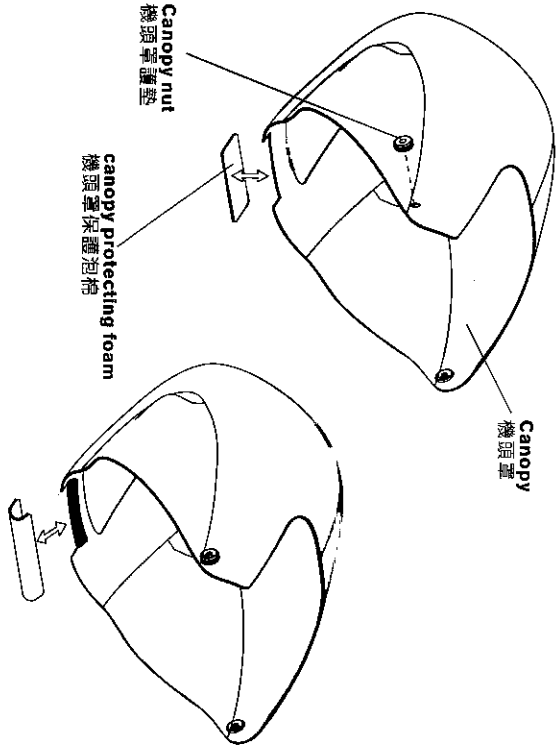
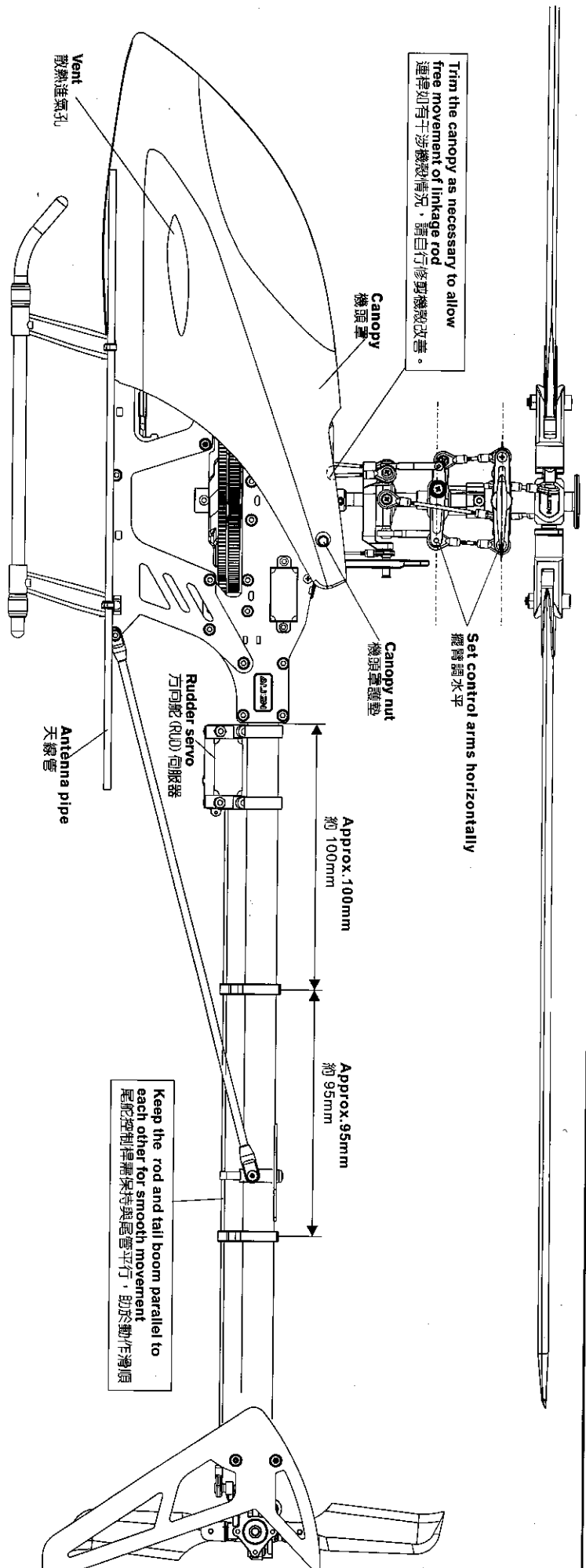

First clean the taping surface of canopy, and then tape a canopy protecting foam on as illustration. 先將機頭罩貼合面擦拭乾淨，再使用機頭罩保護泡棉貼附於上圖所示

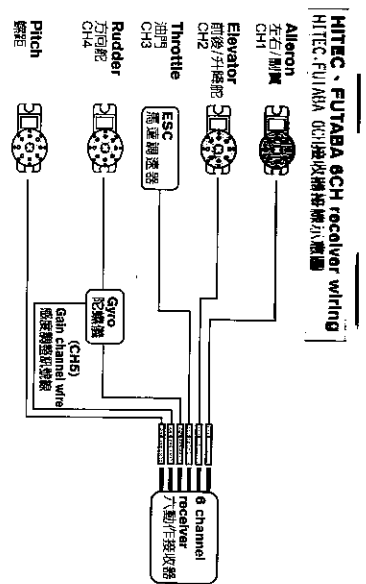

8-Channel Receiver is adequate for the requirements of the T-REX heli. You will need the following channels at a minimum: Throttle, Rudder, Elevator, Aileron, and especially Pitch(CH5) and Gyro(CH5) controls. 六動作接收機已足夠應對T-REX直昇機系統的需求。除了油门、方向舵、副翼等基本動作外，亦可以對機身傾斜感測器接收線路(CH5)與陀螺儀(CH5)。

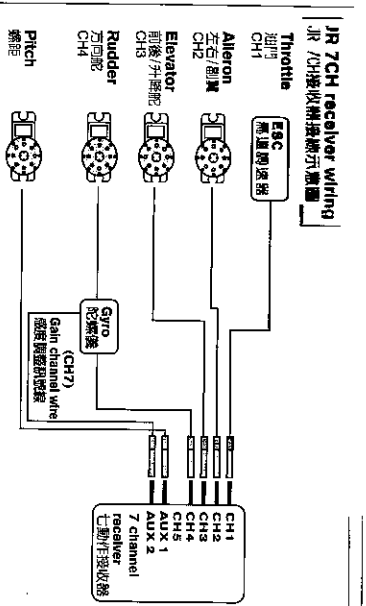

7-Channel Receiver is adequate for the requirements of the T-REX heli. You will need the following channels at a minimum: Throttle, Rudder, Elevator, Aileron, and especially Pitch(AUX 1) and Gyro(AUX 2) controls. 七動作接收機已足夠應對T-REX直昇機系統的需求。除了油门、方向舵、副翼等基本動作外，亦可以對機身傾斜感測器接收線路(AUX 1)與陀螺儀(AUX 2)。

To set this option is to turn on the transmitter and connect to the helicopter power. Note: For the safety, please do not connect ESC to the brushless motor before the setting to avoid the motor running and cause the accident during the setting.
 此項設定只要開啓發射器，接上直昇機電源即可進行操作。注意：為了安全起見，設定前請先不要將無刷調速器與無刷馬達的三條線接上，以免調整時啓動馬達而發生危險。

JR Transmitter/Servo JR遙控器對應伺服器關係

If any interference caused by rod(N) and outer covering, please install the ball links inside.
 若連桿(前)端之連桿頭與機殼會碰觸，則請選擇頭裝置於內側。

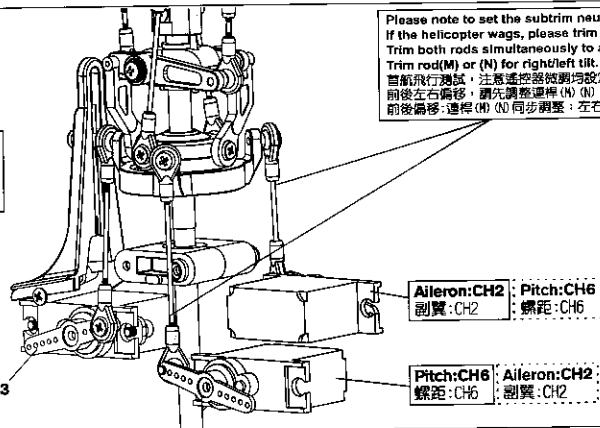

Positions of CH2 · CH6 are exchangeable, After assembling as photo (Note:Set the transmitter under CCPM 120 degrees mode), pull throttle stick (pitch) upward. If one swashplate servo (or two servos) moves downward, adjust reverse switch (REV) on the transmitter to make it moves upward. If three servo move downward, adjust the travel value (+) of SWASH CH6 on the transmitter to make them move upward. When the actions of Aileron and Elevator are opposite, adjust travel values of SWASH CH2 and CH3.

CH2 · CH6可互換配置，依圖連結後(注意：遙控器須設定於CCPM 120°十字盤模式)，將油門搖桿(Pitch)往上推，若十字盤伺服器有1個或2個往下移時，請調整遙控器的反轉開關(REV)使伺服器往上，若3個伺服器同時往下移時，請調整遙控器 SWASH CH6 行程量之正負值，使伺服器同時往上移時，調整與前後動作相反時，同樣調整 SWASH CH2 · CH3 行程量正負值。

FUTABA/HITEC Transmitter/Servo FUTABA/HITEC遙控器對應伺服器關係

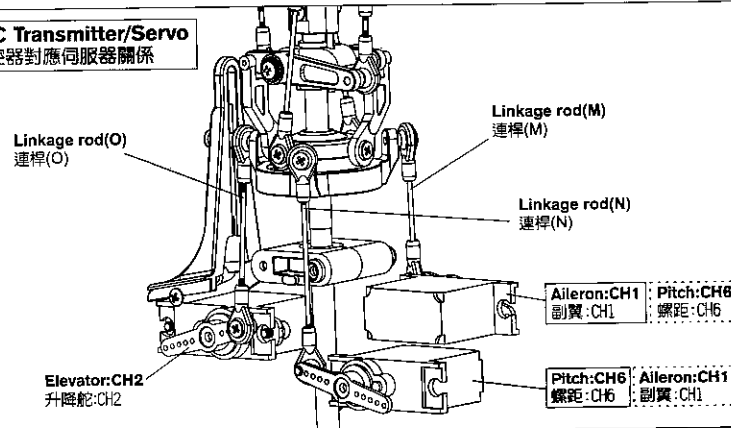

Positions of CH1 · CH6 are exchangeable, After assembling as photo (Note:Set the transmitter under CCPM 120 degrees mode), pull throttle stick (pitch) upward. If one swashplate servo (or two servos) moves downward, adjust reverse switch (REV) on the transmitter to make it moves upward. If three servo move downward, adjust the travel value (+) of SWASH CH6 on the transmitter to make them move upward. When the actions of Aileron and Elevator are opposite, adjust travel values of SWASH CH1 and CH2.

CH1 · CH6可互換配置，依圖連結後(注意：遙控器須設定於CCPM 120°十字盤模式)，將油門搖桿(Pitch)往上推，若十字盤伺服器有1個或2個往下移時，請調整遙控器的反轉開關(REV)使伺服器往上，若3個伺服器同時往下移時，請調整遙控器 SWASH CH6 行程量之正負值，使伺服器同時往上移時，調整與前後動作相反時，同樣調整 SWASH CH1 · CH2 行程量正負值。

12.ADJUSTMENTS FOR GYRO AND TAIL NEUTRAL SETTING 陀螺儀與尾翼中立點設定調整

Recommend to choose Head Lock type for Gyro and turn off Revolution mixing(RVMX) mode on the transmitter, then set the gain switch on the transmitter and the gyro to Head lock mode. The gain setting is about 70%, and after transmitter setting, connect to the helicopter power for working on tail neutral setting. Note: When connecting to the helicopter power, please do not touch tail rudder stick and the helicopter. Then wait for 3 seconds, make tail servo horn and tail servo at a right angle(90 degrees), tail pitch assembly must be correctly fixed about in the middle of the travel of tail rotor shaft for standard neutral setting.

陀螺儀選擇，建議選用鎖定式陀螺儀，且發射器內陀螺儀設定請關閉根軸混控模式，並將發射器上的感度開關與陀螺儀切至鎖定模式，感度設約 70% 左右，發射器設定完成後接上直昇機電源，即可進行尾中立點設定。注意：當接上直昇機電源時請勿撥動尾舵搖桿或碰觸機體，待3秒陀螺儀鎖定後尾伺服器需與尾舵伺服器成 90°，尾旋翼控制組須正確置於尾橫軸行程約中間位置，即為標準尾中立點設定。

TAIL NEUTRAL SETTING 尾中立點設定

After setting Head Lock mode, correct setting position of tail servo and tail pitch assembly is as photo. If the tail pitch assembly is not in the middle position, please adjust the length of rudder control rod to trim.
 陀螺儀鎖定後尾伺服器與尾 Pitch 控制組正確擺置位置。若尾 Pitch 控制組未置中時請調整尾控制連桿的長度來修正。

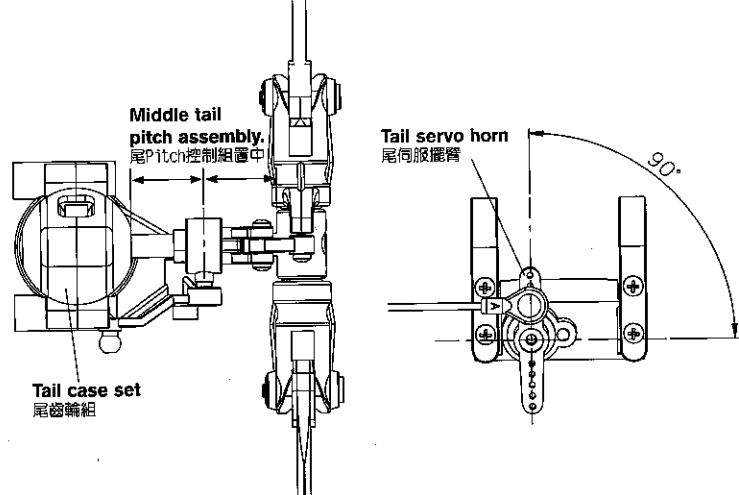

HEAD LOCK DIRECTION SETTING OF GYRO 陀螺儀鎖定方向設定

To check the head lock direction of gyro is to move the tail counterclockwise and the tail servo horn will be trimmed clockwise. If it trims in the reverse direction, please switch the gyro to "REVERSE".
 陀螺儀鎖定方向確認，當手搖尾部反時鐘擺動，尾伺服器臂應順時鐘修正，反向時請切換陀螺儀上「鎖定反向」開關修正。

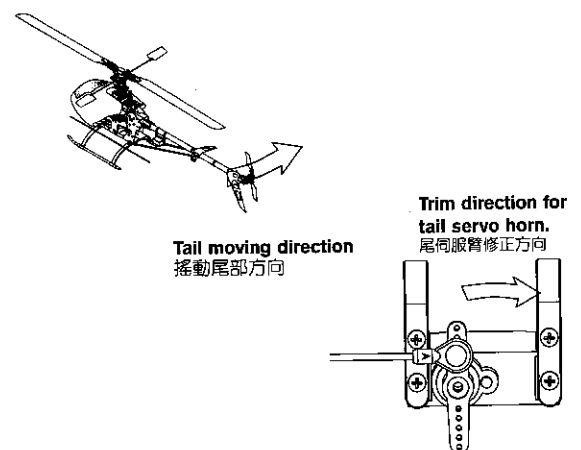

GENERAL FLIGHT 一般飛行模式

Stick position at high/Throttle 100%/Pitch +9°~+11°
搖桿高速/油門100%/螺距+9°~+11°

Stick position at Hovering/Throttle 65%~70%/Pitch +5°~+6°
搖桿停懸/油門65%~70%/螺距+5°~+6°

Stick position at low/Throttle 0%/Pitch 0°
搖桿低速/油門0%/螺距0°

GENERAL FLIGHT 一般飛行模式

	Throttle 油門	Pitch 螺距
5	100% High speed 100% 高速	+9°~+11°
4	85%	
3	65%~70% Hovering 65%~70% 停懸	+5°
2	40%	
1	0% Low speed 0% 低速	0°

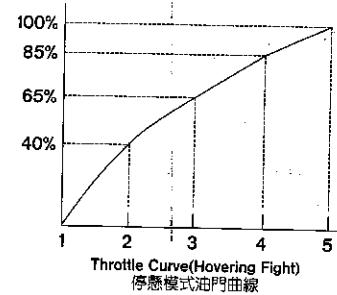

Pitch and Rotation Speed Pitch與轉速關係
TIP: It is recommended to use a lower pitch setting when using higher RPM/Head speed. This will allow for better power.
搭配要領: 如果使用較高轉速馬達動力建議搭配調低 Pitch, 將獲得較佳動力效能。

3D FLIGHT 3D特技飛行模式

Stick position at high/Throttle 100%/Pitch +9°~+11°
搖桿高速/油門100%/螺距+9°~+11°

Stick position at middle/Throttle 90%/Pitch 0°
搖桿中速/油門90%/螺距0°

Stick position at low/Throttle 100%/Pitch -8°~-10°
搖桿低速/油門100%/螺距-8°~-10°

IDLE 1: SPORT FLIGHT

	Throttle 油門	Pitch 螺距
5	100%	+9°~+11°
4	85%	
3	80%	+5°
2	85%	
1	90%	-5°

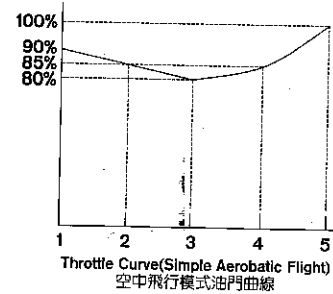

IDLE 2: 3D FLIGHT

	Throttle 油門	Pitch 螺距
5	100% High 100% 高	+9°~+11°
3	90% Middle 90% 中	0°
1	100% Low 100% 低	-9°~-11°

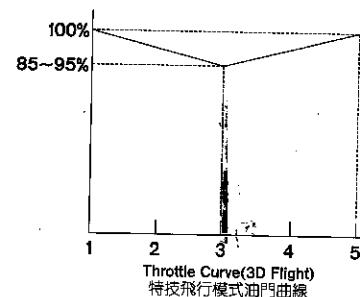

1. Pitch range: Approx. 25 degrees.
 2. If the pitch is set too high, it will result in shorter flight duration and poor motor performance.
 3. Setting the throttle to provide a higher speed is preferable to increasing the pitch too high.
1. 螺距 (Pitch) 總行程約 25°
 2. 過大螺距設定, 會導致動力與飛行時間降低。
 3. 動力提升以較高轉速的設定方式, 優於螺距調大的設定。



Battery 電池: ALIGN Li-Poly 11.1V 2100mAh 22C

Motor Gear 馬達主齒	Main Rotor Blade 主旋翼規格	PITCH 螺距		Current(A) approx. 電流(A) 大約值	Throttle Curve 油門曲線	RPM approx. 主旋翼轉速 大約值	
12T	325mm 3K Carbon blade 3K碳纖主旋翼	Hover 停懸	+5°	7.4	0/50/65/85/100%	2193	
		Idle 2	0°	12.8		100/100/100/100/100%	3280
			±9°	31.0			2753
13T	325mm 3K Carbon blade 3K碳纖主旋翼	Hover 停懸	+5°	7.5	0/50/60/85/100%	2290	
		Idle 2	0°	14.1		100/100/100/100/100%	3450
			±9°	33.0			2850

Note: Please use the pitch gauge to adjust the pitch value. Incorrect pitch setting may affect the helicopter performance and reduce ESC's life and battery's life.

註: 請務必使用螺距規來量測調整螺距, 不正確的設定不但無法發揮直昇機的特性, 更會影響到無刷調速器與電池的壽命。

15. POWER SYSTEM RECOMMENDATION FOR STANDARD EQUIPMENT 原裝動力搭配建議

Align RCM-BL430XL 3700KV high efficiency brushless motor

When hovering, general, 3D flights, recommend to use motor gear 12T, and Max. Pitch +9° ~ +10° for beginner/intermediate pilot.

For hard 3D flight, recommend to use motor gear 13T, and Pitch setting at ±10° ~ 11°

亞拓RCM-BL430XL 3700KV高效率無刷馬達

初中階者飛行停懸、空中、3D飛行模式, 建議搭配12T馬達主齒, Pitch+9° ~ +10°

暴力3D飛行模式建議搭配13T馬達主齒, Pitch設 ±10° ~ 11°

16. RCE-BL35X ESC SETTING SUGGESTION 無刷調速器程式設定建議:

◎ Brake Option: When flying helicopters, select "Brake disable(1-1)".

第一項剎車設定: 使用於直昇機時務必設定在(1-1) "無剎車" 模式。

◎ Timing Option: When using BL430XL brushless motor, select "Mid-timing(2-2) to get better efficiency. If select "High-timing(2-3) to increase power, it will increase current and cause power consumption.

第二項進角設定: 搭配BL430XL無刷馬達時, 請設定於(2-2) "中進角", 以獲得較佳的效率; 若設定為高進角雖可提升動力輸出, 但會因電流提高而較為耗電。

◎ Battery Protection Option: Will cause the motor to pulse, this notifies pilots of low voltage in battery. For 3D flight, recommend to select "Middle cutoff voltage protection (3-2)" to avoid low voltage to prematurely damage the battery; For beginner to practice hovering or do a general flight, recommend to select "High cutoff voltage protection (3-1)". To avoid the low voltage caused by battery over-discharging.

第三項電池截止電壓保護設定: 3D飛行模式建議設定在(3-2) "中截止電壓" 保護, 以避免特技飛行時因電流較高, 產生較大的壓降而提早啟動截止電壓保護; 初學者僅作停懸練習或一般飛行模式時請將設定改為(3-1) "高截止電壓保護", 以免對電池過放造成電壓偏低而影響電池壽命。

NOTE: Please use full-charged battery to fly. If the battery is not full-charged, ESC may erroneously set the cut-off voltage and cause the battery over-discharged.

注意: 飛行時務必使用已充飽之電池, 若電池未充飽或電壓過低的電池, 可能會造成電變誤判保護截止電壓, 而有造成電池過放電之可能。

◎ Aircraft Option: Default setting is "Helicopter 1 (4-2)" and this option provides Soft Start. You can select "Normal Airplane (4-1)" to cancel this option, or select "Helicopter 2 (4-3)" and this option provides Soft Start and Governor Mode.

第四項飛機模式: 本變速器初始值已設定為(4-2) "直昇機模式", 具有緩啟動功能, 若欲取消此功能可更改設定為(4-1) "飛機模式" 或(4-3) "直昇機模式2" 具有緩啟動及定速功能。

◎ Throttle response speed: Default setting is "Quick throttle response (5-3)", suitable for 3D flight. The user can change to the other options according to the demand, "Standard throttle response (5-1)" or "Medium throttle response (5-2)" for soft response speed.

第五項油門反應速度設定: 初始設定為(5-3) "高油門反應速度", 適合3D飛行; 使用者可依需求自行修改設定(5-1) "標準油門反應速度" 或(5-2) "中油門反應速度", 可使油門的反應較為柔和。

PLEASE PRACTICE SIMULATION FLIGHT BEFORE REAL FLYING 飛行前請事先熟練模擬飛行

Do a simulation flight until you familiarize your fingers with the movements of the rudders, and keep practicing until the fingers move naturally.

1. Place the helicopter in a clear open field (Make sure the power OFF) and the tail of helicopter point to yourself.
2. Practice to operate the throttle stick(as below illustration) and repeat practicing "Throttle high/low", "Aileron left/right", "Rudder left/right", and "Elevator up/down".
3. The simulation flight practice is very important, please keep practicing until the fingers move naturally when you hear operation orders being call out.
4. Another safe and effective practice method is to use the transmitter flying on the computer through simulator software sold on the market.

在還沒瞭解直昇機各動作的操控方式前，嚴禁遙電飛行，請先進行模擬飛行的練習，並不斷的重複，直到手指可熟練的控制各個動作及方向。

1. 將直昇機放在空曠的地方(確認電源為關閉)，並將直昇機的機尾對準自己。
2. 練習操作遙控器的各搖桿(各動作的操作方式如下圖)，並反覆練習油門高/低、副翼左/右、升降舵前/後及方向舵左/右操作方式。
3. 模擬飛行的練習相當重要，請重複練習直到不需思索，手指能自然隨著喊出的指令移動控制。
4. 另外一種最有效、最安全的練習方式，就是透過市面販售的模擬軟體，以遙控器在電腦上模擬飛行，熟悉各種方向的操控。

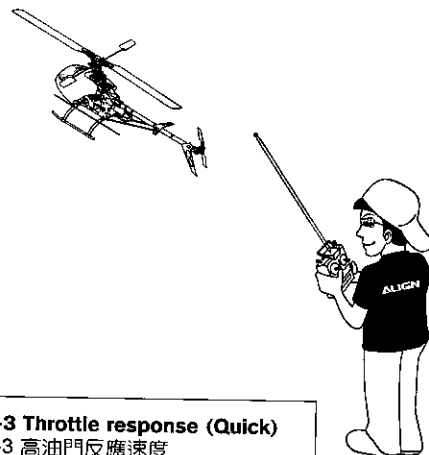

ESC setting (RCE-BL35X):

調速器設定建議:

1-1 Brake Disable

1-1 煞車

2-2 Mid timing

2-2 中進角

3-2 Battery Protection(Middle)

3-2 中電池截止電壓保護

4-2 Helicopter 1

4-2 直昇機模式1

5-3 Throttle response (Quick)

5-3 高油門反應速度

Mode 1	Mode 2	Illustration圖示
<p>Aileron 副翼</p>		
	<p>Elevator 升降/前後</p>	
	<p>Throttle 油門</p>	
	<p>Rudder 方向</p>	

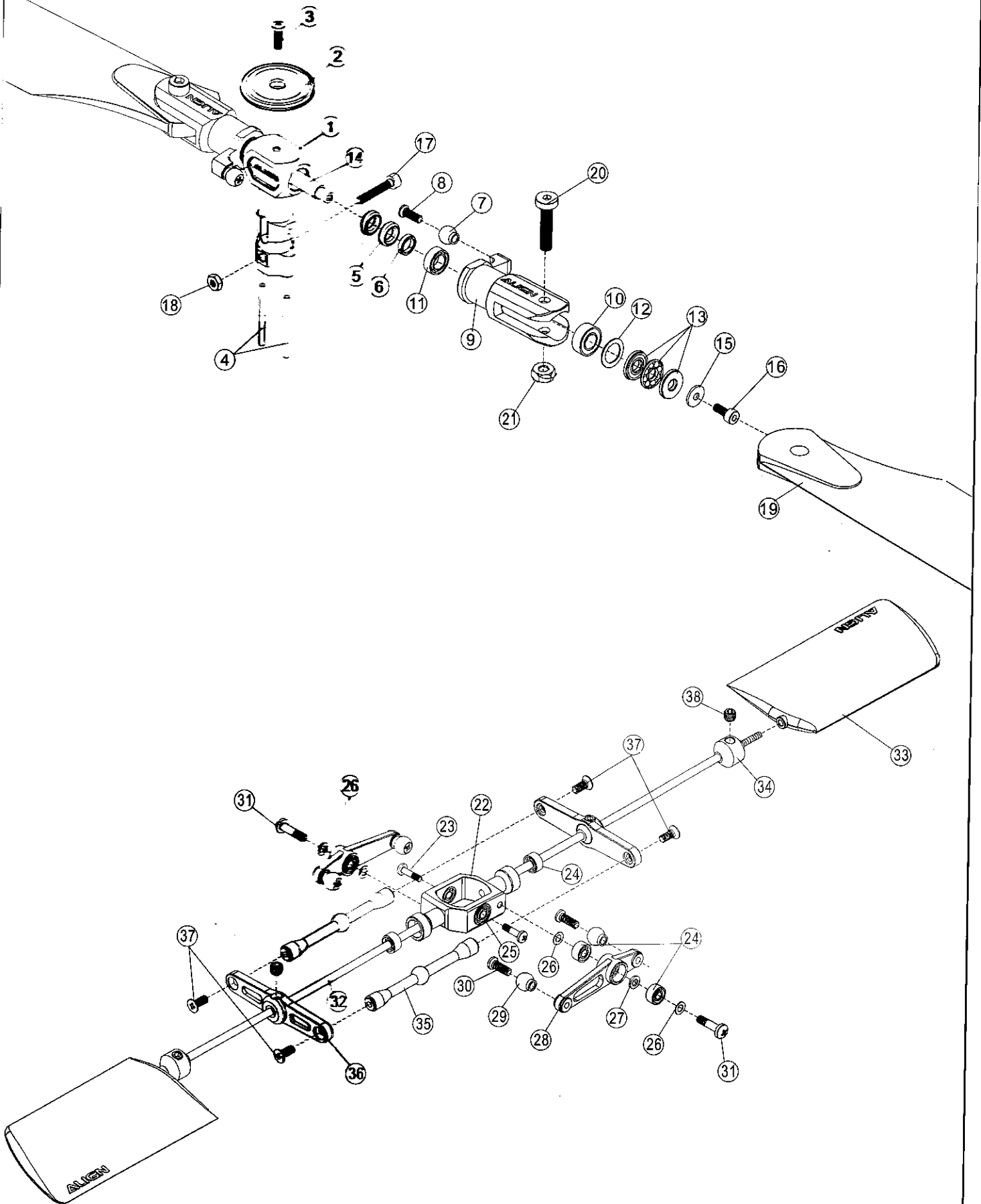

No.	Code No.	Name	Specification	Quantity	Remarks
1	HH2015	Metal main rotor housing 金屬主旋翼固定座	17x37.5x11mm	1	
2	HH2014	Metal head stopper 金屬旋翼頭制動器	φ 19.9X6mm	1	
3	T12006	Screw 圓頭十字螺絲	M2X6mm	1	
4	HH2003-1	Pin 定位插銷	φ 1.5X18.7mm	2	
5	HH2018	450V2 Damper rubber 450V2橫軸墊圈	φ 4X φ 6.5X2mm	4	
6	HH2019	450V2 Aluminum collar 450V2橫軸鋁套	φ 4X φ 5.6X1.5mm	2	
7	HH4006S	Stainless steel linkage ball 不銹鋼球頭	φ 4.75	2	
8	S72007-1	Cross screw 皿頭十字螺絲	M2X6.5mm	2	
9	HH2017	V2 Metal main rotor holder V2金屬主旋翼夾座	φ 7X36.65X10.5mm	2	
10	HMR84ZZ	Bearing MR84ZZ 軸承MR84ZZ	φ 4X φ 8X3mm	2	
11	50HMR74ZZ	Bearing MR74ZZ 軸承MR74ZZ	φ 4X φ 7X2.5mm	2	
12	W10055-1	Washer 華司	φ 5.5X φ 8X0.4mm	2	
13	HH2016	Thrust bearing 止推軸承	φ 3X φ 8X3.5mm	2	
14	HH2020	450V2 Feathering shaft 450V2橫軸	φ 4X41mm	1	
15	W10020	Washer 華司	φ 2X φ 6X0.6mm	2	
16	T62006	Socket screw 圓頭內六角螺絲	M2X6mm	2	
17	T52012	Socket screw 圓頭內六角螺絲	M2X12mm	1	
18	N10020-1	Nut 螺帽	M2	1	
19	KU110005	325 Carbon rotor blade 325碳纖維主旋翼	325mm	1set	
20	T53014-1	Socket screw 圓頭內六角螺絲	M3X14mm	2	
21	N10030	Nut M3防鬆螺帽	M3	2	
22	HH4002L-1	Metal flybar seesaw holder 金屬平衡桿固定座	36X14.5X7mm	1	
23	T12065	Collar screw 軸套螺絲	M2X6.5mm	2	
24	HMR52ZZ	Bearing MR52ZZ 軸承MR52ZZ	φ 2X φ 5X2.5mm	6	
25	HFMR52ZZ	Bearing FMR52ZZ 軸承FMR52ZZ	φ 2X φ 5X φ 6X2.3mm	2	
26	W10020-1	Washer 華司	φ 2X φ 3.6X0.2mm	4	
27	W10020-2	Washer 華司	φ 2X φ 3.6X0.5mm	2	
28	HH4005AL	Metal SF mixing arm 金屬SF控制搖臂	31.45X5.5mm	2	
29	HH4006S	Stainless steel linkage ball 不銹鋼球頭	φ 4.75	4	
30	S72007-1	Cross screw 皿頭十字螺絲	M2X6.5mm	4	
31	T12008-2	Collar screw 軸套螺絲	M2X8mm	2	
32	HH4003-2	Flybar rod 平衡翼桿	φ 1.97X220mm	1	
33	HH4022	Flybar paddle 平衡翼		2	
34	HH4018	Flybar weight 平衡翼重錘	φ 7.5X8mm	2	
35	HH4012S	Flybar control rod 平衡翼控制球桿	φ 4.3X39mm	2	
36	HH4014	Flybar control arm 平衡翼T型控制臂	38.3X4.5mm	2	
37	S72005-3	Cross screw 皿頭十字螺絲	M2X5mm	4	
38	T73003	Set screw 止洩螺絲	M3X3mm	4	

Specifications, contents of parts and availability are subject to change, Align RC is not responsible for inadvertent errors in this publications.
 本說明書內的材質、規格或零件包裝之內容物僅供參考。本公司將不對此印刷物之異動負責，也無法主動通知消費者，任何更新或異動，請以亞拓網頁為主。

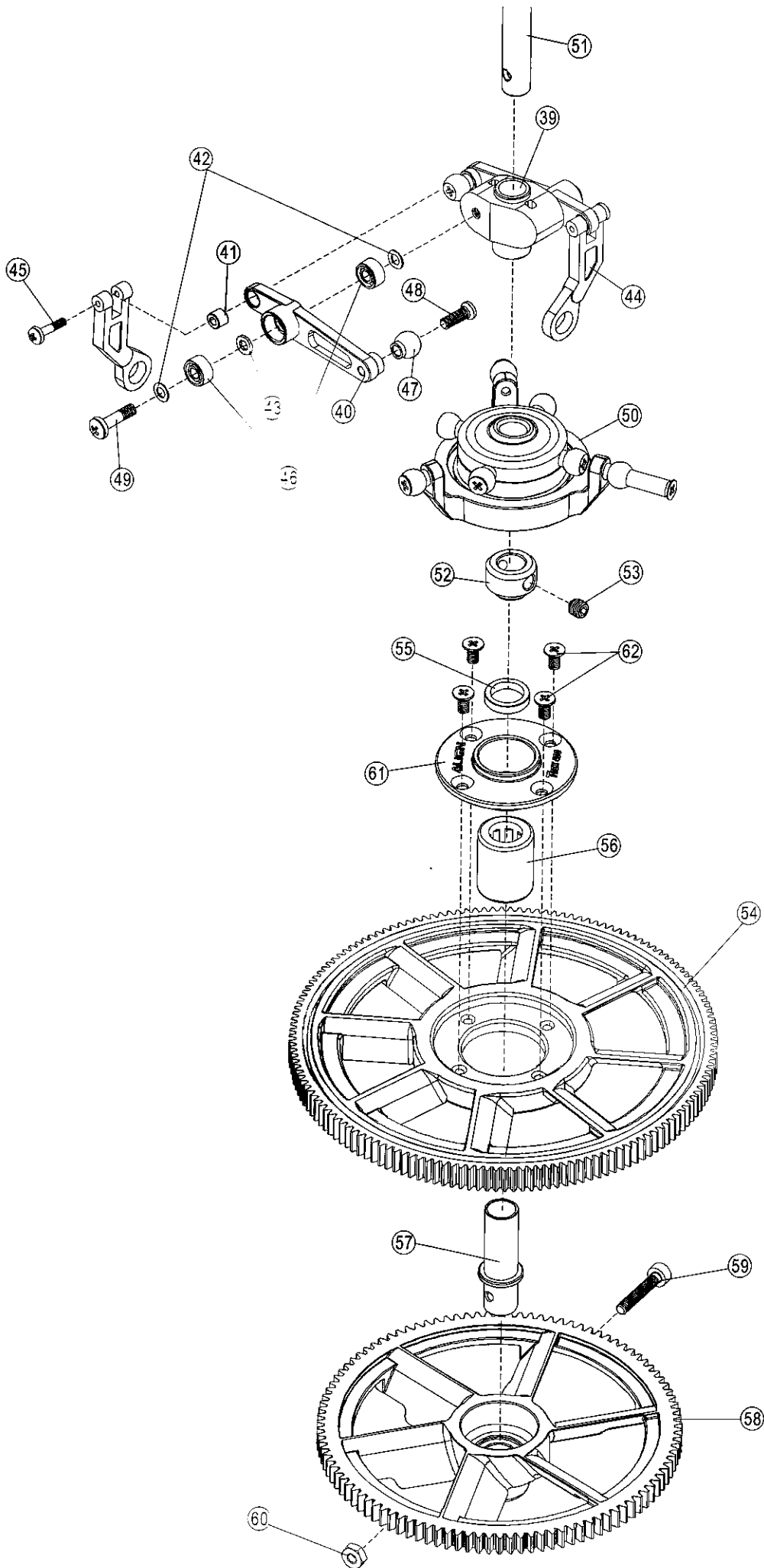

No.	Code No.	Name	Specification	Quantity	Remarks
39	HH5002L-1	Metal washout base 金屬向位器	16X13X10mm	1	
40	HH5003AL-1	Metal washout control arm 金屬穩定控制搖臂	32.5X5.5mm	2	
41	HH5008	Collar 穩定翼控制臂銅套	φ 1.4X φ 3X2.4mm	2	
42	W10020-1	Washer 華司	φ 2X φ 3.6X0.2mm	4	
43	W10020-2	Washer 華司	φ 2X φ 3.6X0.5mm	2	
44	HH5003B-3	Radius arm Radius連桿		2	
45	S41465	Collar screw 軸套螺絲	M1.4X6.5mm	2	
46	HMR52ZZ	Bearing MR52ZZ 軸承MR52ZZ	φ 2X φ 5X2.5mm	4	
47	HH4006S	Stainless steel linkage ball 不銹鋼球頭	φ 4.75	2	
48	S72007-1	Cross screw 皿頭十字螺絲	M2X6.5mm	2	
49	T12008-2	Collar screw 軸套螺絲	M2X8mm	2	
50	HH5004A-5	CCPM Swashplate CCPM十字盤組		1set	
51	HH6002-2	Main shaft 主軸	φ 5X116mm	1	
52	HH6003	Lock ring 主軸固定套	φ 5X6mm	1	
53	T73003	Set screw 止洩螺絲	M3X3mm	1	
54	HB6006	New main drive gear 新型主齒輪	150T	1	
55	HB6003-2	One-way shaft ring 單向軸套圈	φ 6X φ 8X1.6mm	1	
56	HF0612-1	One-way bearing 單向軸承	φ 6X φ 10X12mm	1	
57	HB6002	One-way bearing shaft 單向軸承套	φ 5X φ 6X21.5mm	1	
58	HB6007	New autorotation tail drive gear 新型尾驅動主齒	106T	1	
59	T52012	Socket screw 圓頭內六角螺絲	M2X12mm	1	
60	N10020-1	Nut 螺帽	M2	1	
61	HB6008	450 Main gear case 450主齒中心座	φ 10X φ 21.5X7.8mm	1	
62	S72004-1	Cross screw 皿頭十字螺絲	M2x4mm	4	

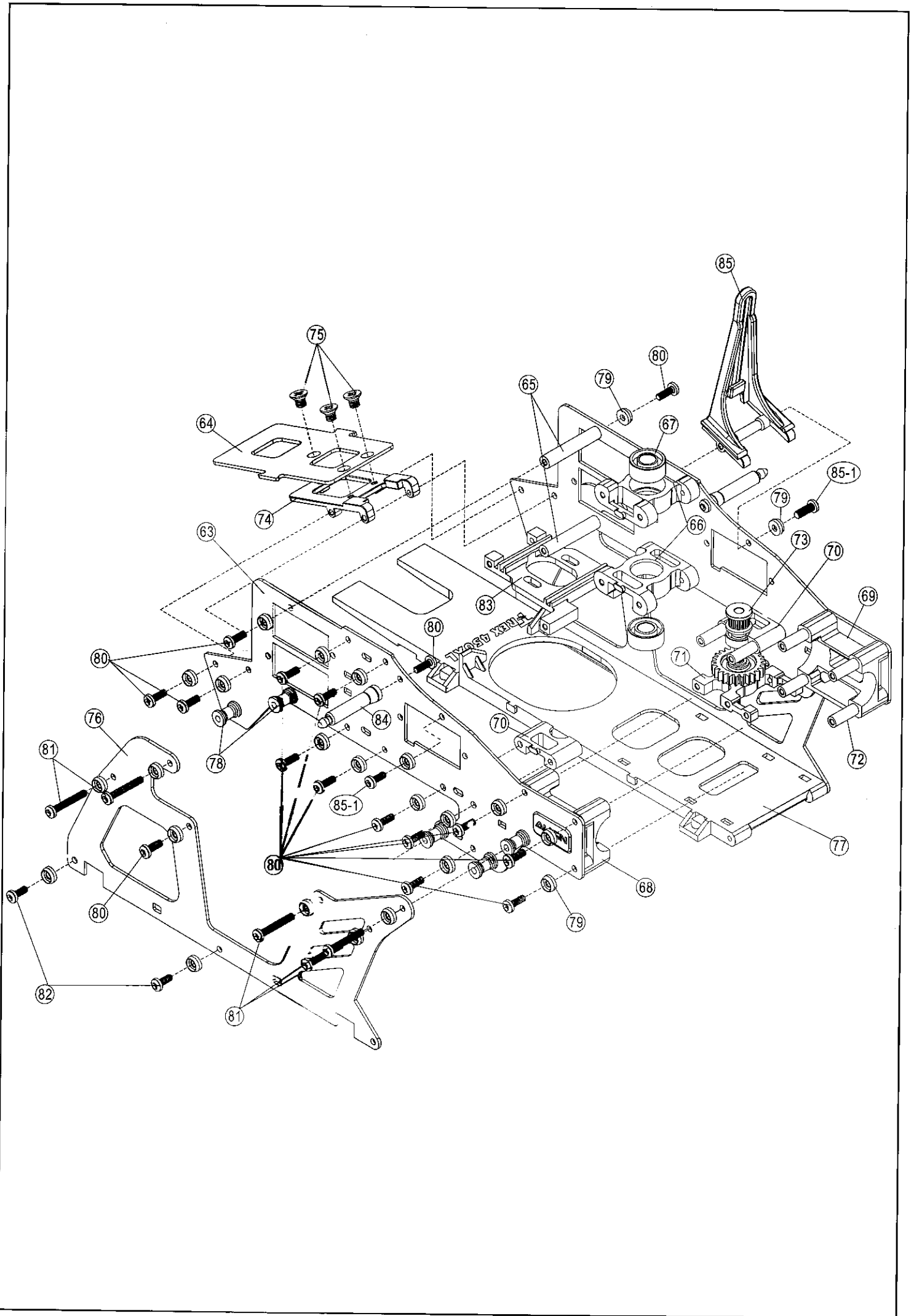

No.	Code No.	Name	Specification	Quantity	Remarks
63	HB2024	450V2 Upper frame 450V2上側板	161.95X58.25X1mm	2	
64	HB2026	450V2 Battery mounting plate 450V2電池座	54X34X1mm	1	
65	HB2005CF	Frame mounting bolt 機身鋁固定柱	φ 4X22mm	2	
66	HB9001CF	Metal main shaft block 金屬主軸固定座	23X22X7mm	2	
67	H685ZZ	Bearing 685ZZ 軸承685ZZ	φ 5X φ 11X5mm	2	
68	HB1112	Metal tail boom mount(L) 金屬尾管固定座(左)	27.5X21.7X11.5mm	1	
69	HB1113	Metal tail boom mount(R) 金屬尾管固定座(右)	27.5X21.7X11.5mm	1	
70	HB1110CF-1	Metal upper bearing block 金屬尾組培林上固定座	18X11X3.5mm	2	
71	HB1111CF	Metal lower bearing block 金屬尾組培林下固定座	25X22X4mm	1	
72	HB9002CF	Aluminum tube 鋁套管	φ 3.5X19.7mm	6	
73	HB3001-5	Tail drive gear assembly 尾旋翼傳動輪組		1set	
74	HB1002CF-1	Aluminum battery mount 電池鋁座	36X22X5.75mm	1	
75	S72004-1	Cross screw 皿頭十字螺絲	M2X4mm	3	
76	HB2025	450V2 Lower frame 450V2下側板	147X62.5X1mm	2	
77	HB1006CF	Bottom plate 底板	172.5X39X5mm	1	
78	HB2014CF	Aluminum link 上下側板接合鋁柱	φ 2X φ 5X7.5mm	10	
79	HB2015CF	M2 specialty washer M2特殊華司	φ 2X φ 5X2mm	44	
80	T52006	Socket button head screw 半圓頭內六角螺絲	M2X6mm	30	
81	T52014	Socket button head screw 半圓頭內六角螺絲	M2X14mm	10	
82	T52008-1	Socket button head self tapping screw 半圓頭內六角鐵板螺絲	T2X8mm	4	
83	HB1001CF-1	Metal motor mount 金屬馬達固定座	36.4X39mm	1	
84	HB2006CF	Canopy mounting bolt 機頭罩鋁固定柱	φ 5X24.5mm	2	
85	HB4007-1	Anti rotation bracket spacer 十字盤導板		1	
85-1	T52006-1	Socket button head self tapping screw 半圓頭內六角鐵板螺絲	T2X6mm	2	

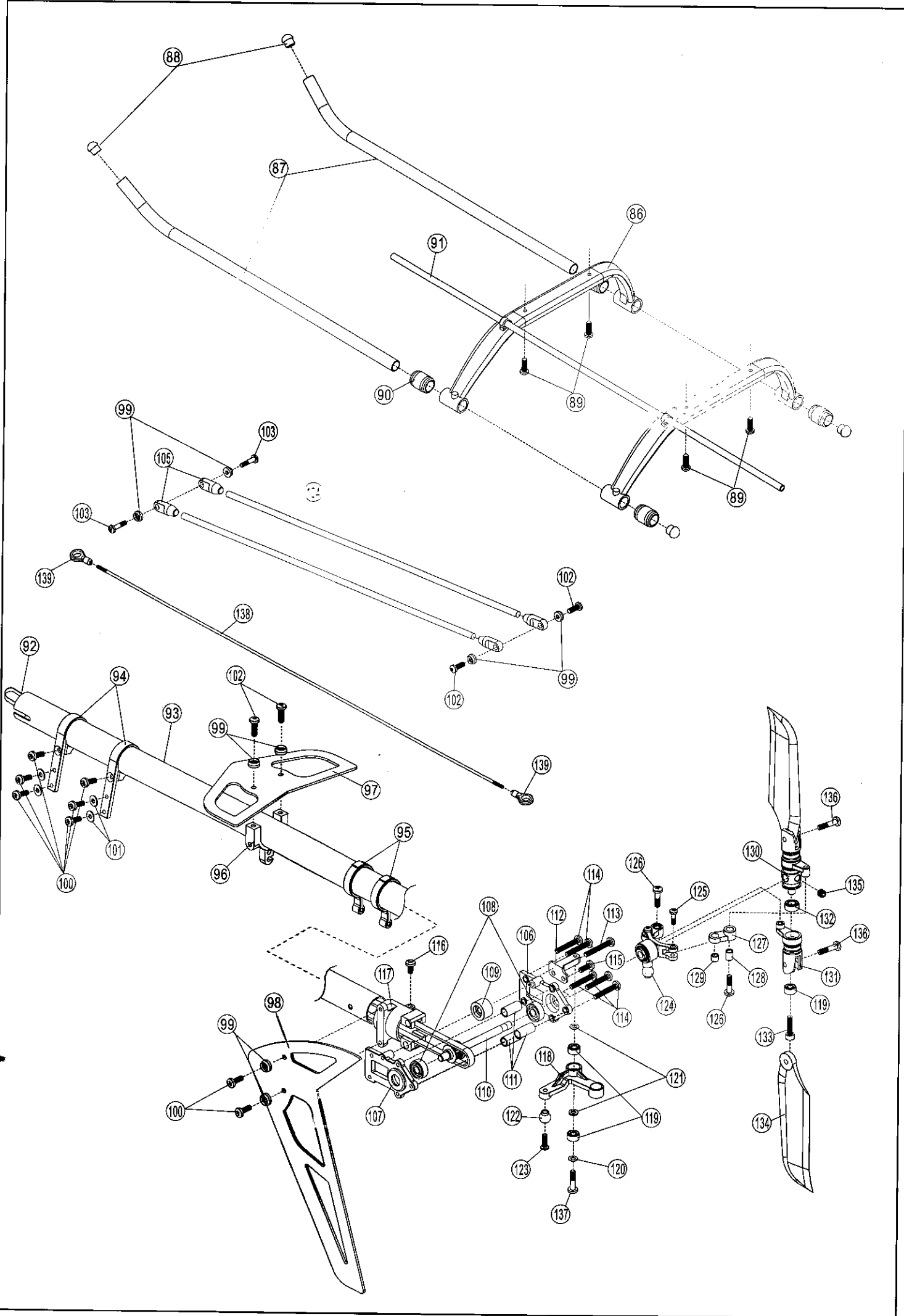

No.	Code No.	Name	Specification	Quantity	Remarks
86	HF2002-2	Landing skid	腳架	2	
87	HF2003	Skid pipe	腳架鉛管 φ 5.5X180mm	2	
88	HF2004	Skid pipe end cap	腳架鉛管保護套 φ 4.5X φ 2.5mm	4	
89	T52008-1	Socket button head self tapping screw	半圓頭內六角鐵板螺絲 T2X8mm	4	
90	K10181-1	Landing skid nut	起落架襯墊 φ 5X φ 8.5X10mm	4	
91	HF2007	Antenna pipe	天線管 φ 3X300mm	1	
92	HT1003	Tail drive belt	尾傳動皮帶 397MXL	1	
93	HT2004	Tail boom	尾管 φ 12X347mm	1	
94	HT2002CF-1	Metal tail servo mount	金屬尾伺服器座	2	
95	HT9004	Tail control guide	尾控制桿固定環 φ 12.2X φ 14.6X4mm	2	
96	HT3003	Stabilizer mount	水平翼固定座	1	
97	HT3009	3K Carbon horizontal stabilizer	3K碳纖維水平翼	1	
98	HT3012	450V2 Carbon vertical stabilizer	450V2碳纖維垂直翼	1	
99	HB2015CF	M2 specialty washer	M2特殊華司 φ 2X φ 5X2mm	8	
100	T52006	Socket button head screw	半圓頭內六角螺絲 M2X6mm	8	
101	W10020	Washer	華司 φ 2X φ 6X0.6mm	4	
102	T52008-1	Socket button head self tapping screw	半圓頭內六角鐵板螺絲 T2X8mm	4	
103	T12009-1	Collar screw	軸套螺絲 M2X9mm	2	
104	HT2003A	Tail boom brace	尾管支撐架 φ 3X205mm	2	
105	HT2003S	Tail boom brace end	金屬尾管支撐架接頭	4	
106	HT4001CF-1	Metal tail unit housing(R)	金屬尾齒輪座(右) 29.5X14.75X3.7mm	1	
107	HT4002CF-1	Metal tail unit housing(L)	金屬尾齒輪座(左) 29.5X14.75X3.7mm	1	
108	HMR83ZZ	Bearing MR83ZZ	軸承MR83ZZ φ 3X φ 8X3mm	2	
109	HT4003CF-1	Tail pulley assembly	尾皮帶導輪組	1set	
110	HT5001CF-1	Tail rotor shaft assembly	尾旋翼主軸組	1set	
111	HT4008CF	Aluminum collar	尾組齒輪座鉛套 φ 3X φ 4X8.5mm	3	
112	HT4007CF	Control arm holder	金屬尾控制臂固定座 11x22mm	1	
113	T52014	Socket button head screw	半圓頭內六角螺絲 M2X14mm	1	
114	T52012-1	Socket button head screw	半圓頭內六角螺絲 M2X12mm	5	
115	T52004	Socket button head screw	半圓頭內六角螺絲 M2X4mm	1	
116	T52006	Socket button head screw	半圓頭內六角螺絲 M2X6mm	1	
117	HT4006CF	Tail gear case	金屬尾組齒輪固定座 φ 14X20X20mm	1	
118	HT4009	Tail rotor control arm	尾旋翼控制臂 18.5x14mm	1	
119	HMR52ZZ	Bearing MR52ZZ	軸承MR52ZZ φ 2X φ 5X2.5mm	4	
120	W10020-1	Washer	華司 φ 2X φ 3.6X0.2mm	1	
121	W10020-2	Washer	華司 φ 2X φ 3.6X0.5mm	2	
122	HH4006S	Stainless steel linkage ball	不銹鋼球頭 φ 4.75	1	
123	S72007-1	Cross screw	皿頭十字螺絲 M2X6.5mm	1	
124		Tail pitch assembly	尾旋翼控制組	1set	
125	T12006-1	Collar screw	軸套螺絲 M2X6mm	2	
126	T12008-4	Collar screw	軸套螺絲 M2X8mm	2	
127	HT7003B	Control ball link	尾控制連桿頭 φ 5.1X11.58X4.2mm	2	
128	50T106	Collar A	尾連桿頭鋼套A φ 2X φ 3X4mm	2	
129	HT7003C	Collar B	尾連桿頭鋼套B φ 2X φ 3X2.5mm	2	
130	HT6001S-2	Tail rotor hub	尾旋翼T型座 φ 8X18.2mm	1	
131	HT6006L-2	Metal tail rotor holder	金屬尾旋翼夾座	2	
132	HMR63ZZ	Bearing MR63ZZ	軸承MR63ZZ φ 3X φ 6X2.5mm	2	
133	T52008	Socket screw	圓頭內六角螺絲 M2X8mm	2	
134	HT6011	Tail rotor blade	尾旋翼 60.75x2.2mm	2	
135	T73003	Set screw	止洩螺絲 M3X3mm	1	
136	T12008-2	Collar screw	軸套螺絲 M2X8mm	2	
137	T12009-1	Collar screw	軸套螺絲 M2X9mm	1	
138	HT9003	Rudder control rod	尾舵控制連桿 φ 1.3X280mm	1	
139	HZ009-1	Ball link(Long)	連桿頭(長)	2	

19.HARDWARE SIZING REFERENCE CHART (ACTUAL SIZE) 五金零件實寸比例名稱對照表

ALIGN

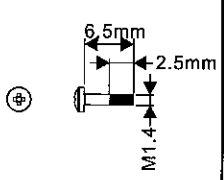
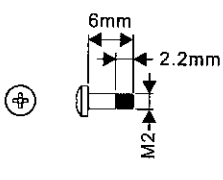
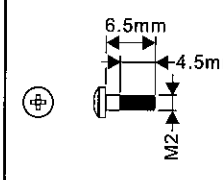
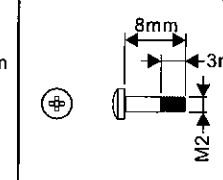
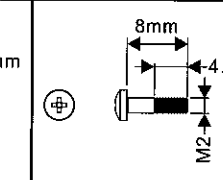
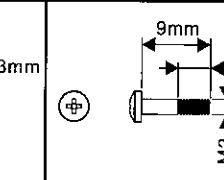
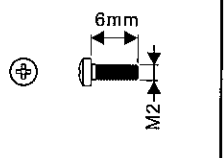
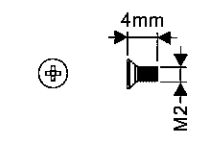
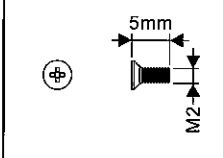
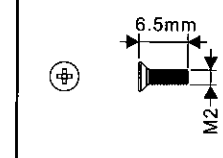
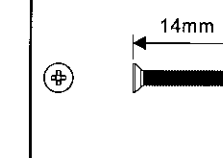
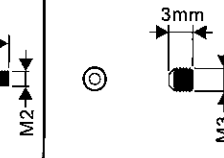
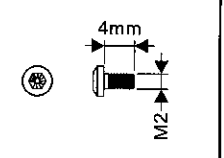
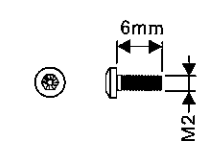
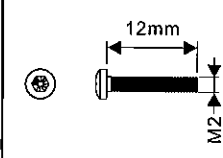
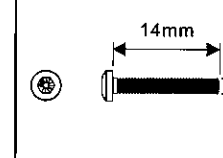
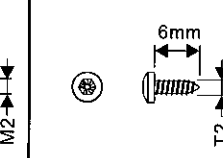
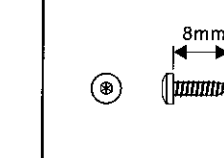
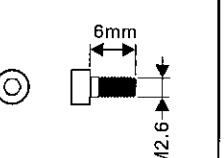
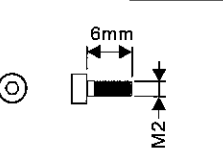
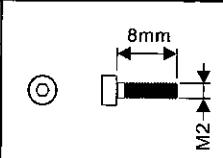
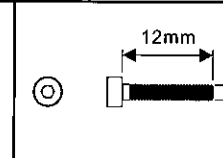
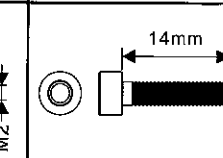
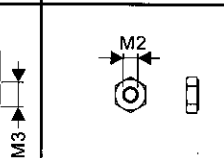
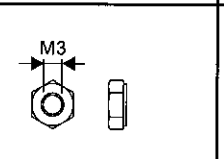
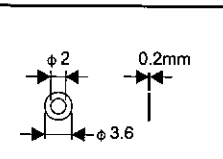
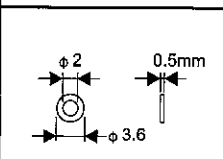
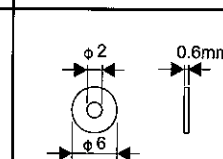
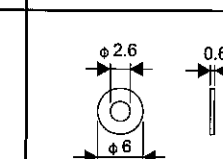
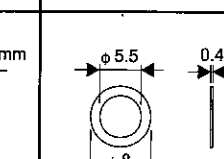
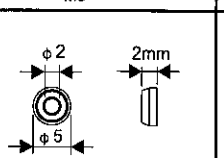
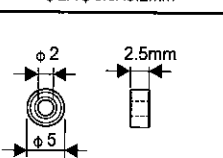
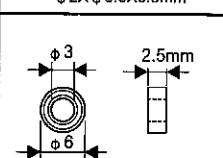
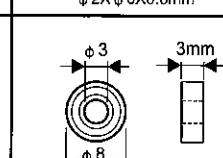
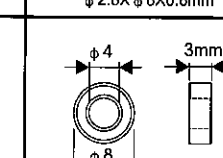
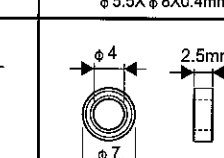
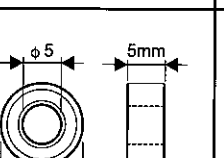
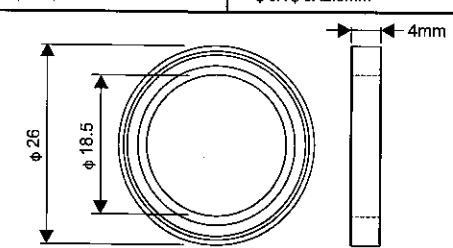
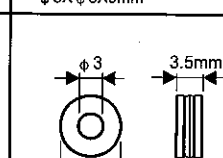
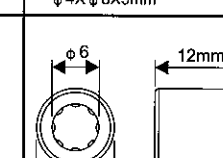
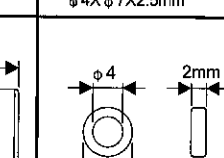
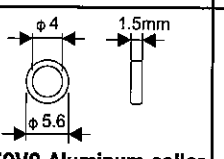
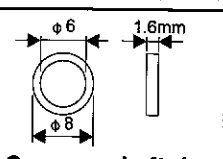
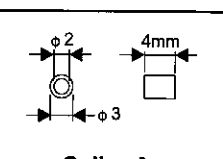
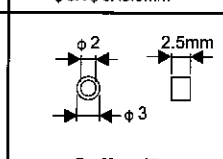
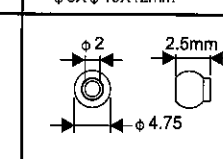
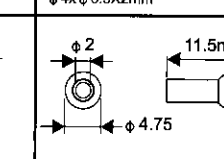
 <p>Collar screw 軸套螺絲 M1.4X6.5mm</p>	 <p>Collar screw 軸套螺絲 M2X6mm</p>	 <p>Collar screw 軸套螺絲 M2X6.5mm</p>	 <p>Collar screw 軸套螺絲 M2X8mm</p>	 <p>Collar screw 軸套螺絲 M2X8mm</p>	 <p>Collar screw 軸套螺絲 M2X9mm</p>
 <p>Screw 圓頭十字螺絲 M2X6mm</p>	 <p>Cross screw 扁頭十字螺絲 M2X4mm</p>	 <p>Cross screw 扁頭十字螺絲 M2X5mm</p>	 <p>Cross screw 扁頭十字螺絲 M2X6.5mm</p>	 <p>Cross screw 扁頭十字螺絲 M2X14mm</p>	 <p>Set screw 止淺螺絲 M3X3mm</p>
 <p>Socket button head screw 半圓頭內六角螺絲 M2X4mm</p>	 <p>Socket button head screw 半圓頭內六角螺絲 M2X6mm</p>	 <p>Socket button head screw 半圓頭內六角螺絲 M2X12mm</p>	 <p>Socket button head screw 半圓頭內六角螺絲 M2X14mm</p>	 <p>Socket button head self tapping screw 半圓頭內六角自攻螺絲 T2X6mm</p>	 <p>Socket button head self tapping screw 半圓頭內六角自攻螺絲 T2X8mm</p>
 <p>Socket screw 圓頭內六角螺絲 M2.6X6mm</p>	 <p>Socket screw 圓頭內六角螺絲 M2X6mm</p>	 <p>Socket screw 圓頭內六角螺絲 M2X8mm</p>	 <p>Socket screw 圓頭內六角螺絲 M2X12mm</p>	 <p>Socket screw 圓頭內六角螺絲 M3X14mm</p>	 <p>Nut 六角螺帽 M2</p>
 <p>Nut 防鬆螺帽 M3</p>	 <p>Washer 華司 φ 2X φ 3.6X0.2mm</p>	 <p>Washer 華司 φ 2X φ 3.6X0.5mm</p>	 <p>Washer 華司 φ 2X φ 6X0.6mm</p>	 <p>Washer 華司 φ 2.6X φ 6X0.6mm</p>	 <p>Washer 華司 φ 5.5X φ 8X0.4mm</p>
 <p>M2 specialty washer M2特殊華司 φ 2X φ 5X2mm</p>	 <p>Bearing MR52ZZ 軸承MR52ZZ φ 2X φ 5X2.5mm</p>	 <p>Bearing MR63ZZ 軸承MR63ZZ φ 3X φ 6X2.5mm</p>	 <p>Bearing MR83ZZ 軸承MR83ZZ φ 3X φ 8X3mm</p>	 <p>Bearing MR84ZZ 軸承MR84ZZ φ 4X φ 8X3mm</p>	 <p>Bearing MR74ZZ 軸承MR74ZZ φ 4X φ 7X2.5mm</p>
 <p>Bearing 685ZZ 軸承685ZZ φ 5X φ 11X5mm</p>	 <p>Bearing 6803ZZ 軸承6803ZZ φ 18.5X φ 26X4mm</p>		 <p>Thrust bearing 止推軸承 φ 3X φ 8X3.5mm</p>	 <p>One-way bearing 單向軸承 φ 6X φ 10X12mm</p>	 <p>450V2 Damper rubber 450V2機軸墊圈 φ 4x φ 6.5X2mm</p>
 <p>450V2 Aluminum collar 450V2機軸鉗套 φ 4X φ 5.6X1.5mm</p>	 <p>One-way shaft ring 單向軸套圈 φ 6X φ 8X1.6mm</p>	 <p>Collar A 尾連桿頭鉗套A φ 2X φ 3X4mm</p>	 <p>Collar B 尾連桿頭鉗套B φ 2X φ 3X2.5mm</p>	 <p>Stainless steel linkage ball 不銹鋼球頭 φ 4.75</p>	 <p>Linkage ball 長型球頭 φ 4.75X11.5mm</p>



Specifications & Equipment/規格配備:

Length/機身長: 660mm

Height/機身高: 230mm

Main Blade Length/主旋翼長: 325mm

Main Rotor Diameter/主旋翼直徑: 700mm

Tail Rotor Diameter/尾旋翼直徑: 150mm

Motor Pinion Gear/馬達主齒: 12T/13T

Main Drive Gear/傳動主齒輪: 150T

Autorotation Tail Drive Gear/尾驅動主齒: 106T

Tail Drive Gear/尾翼傳動齒: 25T

Drive Gear Ratio/齒輪傳動比: 1:12.5:4.24/1:11.5:4.24

Weight(w/o main blade)/空機重: 450g

Flying Weight/全配重: Approx .730~760g

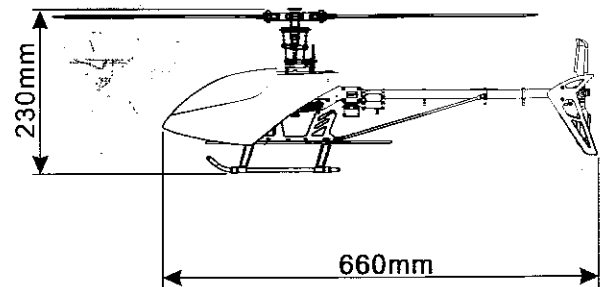
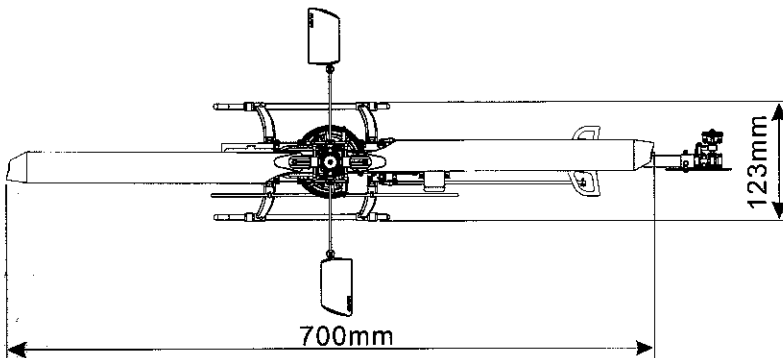

Features:

New head stopper / New ball link design / New main gear set /New Anti rotation bracket / New metal tail servo mount

New vertical/horizontal stabilizers / New main rotor housing and holders / New fiber glass canopy(bigger size)

4mm Feathering shaft w/thrust bearing design / New main frames · New angle of Battery plate · bottom mounting of gyro