

Product Features



1. BEC output voltage (6V) shows great performance on the torque and speed of servo.
2. Three programmable throttle speed settings to support quick throttle response.
3. Include soft start and governor mode.
4. Small and compact PCB design for lightweight and simple installation.
5. Large heat sink for optimum thermal performance.
6. Highly compatible to work with 98% of all brushless motors currently on the market.
7. Ultra-smooth motor start designed to run with all kinds of brushless motors.
8. The power inlet utilizes a Japanese made "Low ESR" capacitor in order to provide stable power source.
9. The BEC power outlet utilizes a Japanese made special polymer aluminum electrolytic capacitor. It provides better noise filtering capability than other brushless ESC on the market, delivering stable performance of R/C receiver and BEC.
10. The BEC features dual TO-252 package regulators. They provide superior thermal performance with 2A peak current.
11. The throttle has more than 200 step resolution that provides great throttle response and control.

Specification

Model	Continuous Current	Peak Current	BEC Output	Dimension	Weight
RCE-BL25X	25A	35A	2A: 2cells Lithium/6-7cells Ni-Mh → 4 servos 3cells Lithium/8-9cells Ni-Mh → 3 servos	45 x 22 x 11	23 g
RCE-BL35X	35A	45A	4cells Lithium/10-12cells Ni-Mh → 2 servos	45 x 22 x 12	25 g

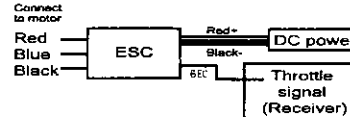

1. Good temperature situation for working at the maximum current
 2. Supporting motor types: 2 ~ 10 pole in/outrunner motors.
 3. Supporting maximum RPM: 2 pole → 190,000 rpm ; 6 pole → 630,000 rpm.
 4. Input voltage: 5.5V ~ 16.8V(Lithium 2~4cells/Ni-Mh 6~12cells)
- Note that when setting to Quick throttle response speed, the accelerative peak current will increase.

Feature options

1. **Brake Option** - 3 settings that include Brake disabled/Soft brake/Hard brake.
2. **Electronic Timing Option** - 3 settings that include Low timing/Mid timing/High timing.
Generally, 2 pole motors are recommended to use low timing, while 6 or more poles should use Mid timing. High timing gives more power at the expense of efficiency. Always check the current draw after changing the timing in order to prevent overloading of battery.
3. **Battery Protection Option**- 3 settings that include Li-ion, Li-poly High/Middle/Low cutoff voltage protection
The default setting is Low cutoff voltage protection (suitable for high discharge current). CPU will automatically determine cell number of input Lithium battery (7.4~16.8V). This option will prevent over-discharge of the battery. The following reference is the guideline for setting the Battery Protection option.
3-1 Li-ion/Li-poly High cutoff voltage protection-When the voltage of single cell drops to 3.2V, the first step of battery protection mode will be engaged by the ESC resulting in reduced power. The pilot should reduce the throttle and prepare landing. If the voltage of single cell drops to 2.9V, the second step of battery protection mode will be engaged resulting in power cutoff. (*Note 1)
For 11.1V/3cells Lithium battery, the full charged voltage will be approximately 12.6V. According to this input voltage, CPU will determine that this is a 3cell battery.
First step protection: 3.2V x 3cell=9.6V
Second step protection: 2.9V x 3cell= 8.7V
When the voltage drops to 9.6V, the power will be reduced. When the voltage drops to 8.7V, the power will be cut off.
3-2 Li-ion/Li-poly Middle cutoff voltage protection- This option is same as instruction 3-1, but when the voltage of single cell drops to 2.9V, the first step of battery protection will be engaged. When the voltage of single cell drops to 2.6V, the second step of battery protection will be engaged. (*Note 1)
3-3 Li-ion/Li-poly Low cutoff voltage protection- This option is same as instruction 3-1, but when the voltage of single cell drops to 2.6V, the first step of battery protection will be engaged. When the voltage of single cell drops to 2.3V, the second step of battery protection will be engaged. (*Note 1)
Note 1: Second step of battery protection only works when Aircraft mode is setting to the option 4-1.
NOTE: THIS OPTION IS ONLY SUITABLE FOR A FULLY CHARGED BATTERY PACK IN GOOD WORKING CONDITION.
4. **Aircraft Option**: 3 settings that include Normal Airplane / Helicopter 1 / Helicopter 2.
Normal Airplane Mode is used for general airplanes and gliders. When flying Helicopters, you can choose Helicopter 1 Mode, or Helicopter 2 Mode. Helicopter 1 Mode provides Soft Start feature. Helicopter 2 Mode provides Soft Start and Governor Mode.
5. **Throttle response speed**: 3 settings that include standard/ Medium/ Quick throttle response speed.
The default setting is standard. Use this option to adjust the setting according to flight character. For example, setting at Medium or Quick speed for 3D and powerful flight to make the power response more quickly, but note the accelerative peak current and power expense will increase.
6. **Thermal Protection**: When the ESC temperature reaches 80°C for any reason, it will engage the battery protection circuit, reducing power to the ESC. We recommend mounting the ESC in a location with adequate air flow and ventilation.
7. **Safe Power On Alarm**: When the operator turns on the ESC, it will automatically detect the transmitter signal.
The ESC will emit a confirmation tone and enter normal operation mode if the throttle is set to the lowest position.
If the throttle position is at full throttle, it will begin to enter Setup Mode. If the throttle is in any other position, the ESC will emit an alarm and not enter into user mode for safety precautions.
8. **Aircraft Locator**: If the aircraft should land or crash in an unexpected location and become lost, the pilot can enable the Aircraft Locator Option. The Aircraft Locator Option is engaged by turning off the transmitter. When the ESC does not receive a signal from the transmitter for 30 seconds, it will start to send an alarm to the motor. The sound of the alarm will aid the pilot to locate the aircraft.
This option will not work with a PCM receiver that has SAVE function enabled, or with low noise resistant PPM receivers.

Setup Mode

- Setup mode:** Make sure to connect the ESC BEC connector to the throttle channel of the receiver. Please refer to the user manual of your radio system. The second step is to connect the 3 power-out signal pins to the brushless motor. Before you turn on the transmitter, please adjust the throttle stick to the maximum full throttle position. Proceed to connect the battery to the ESC. You will hear confirmation sounds as soon as you enter the SETUP MODE. Please refer the attached flow chart for details.
- Throttle stick positions in Setup mode:** Setup mode includes five settings: Brake, Electronic Timing, Battery Protection, Aircraft, and Throttle Response Speed. Every setting has three options. Simply place the throttle stick in the highest, middle, and lowest positions for each setting. For example, first brake setting (Hard): move the stick to the highest position. Then timing setting (mid): move the throttle stick in the middle position.

Mode	Throttle position	Low	Middle	High
Brake		• Brake disabled(1-1)	Soft brake(1-2)	Hard brake(1-3)
Electronic Timing		Low-timing(2-1)	• Mid-timing(2-2)	High-timing(2-3)
Battery Protection		High cutoff voltage protection(3-1)	• Middle cutoff voltage protection(3-2)	Low cutoff voltage protection(3-3)
Aircraft		Normal Airpane/Glider(4-1)	• Helicopter 1 (Soft Start)(4-2)	Helicopter 2 (Soft Start+ Governor Mode)(4-3)
Throttle response speed		Standard(5-1)	Medium speed(5-2)	• Quick speed(5-3)

Note: "•" default setting

User Mode

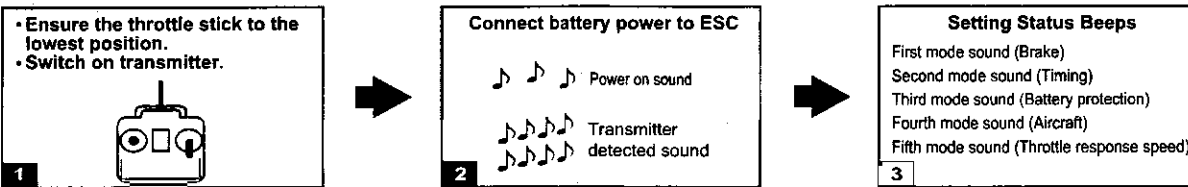

Setup Instruction

First mode sound Brake Status	Second mode sound Electronic Timing Status	Third mode sound Battery protection Status	Fourth mode sound Aircraft Status	Fifth mode sound Throttle response speed status
<ul style="list-style-type: none"> • = Brake disabled • = Soft brake • = Hard brake 	<ul style="list-style-type: none"> • Low timing (apply to 2 pole-runner motors) • Mid timing (apply to 6 pole brush motor) • High timing (apply to high power output) High-timing/big power/power expense 	<ul style="list-style-type: none"> • = High cutoff voltage protection • = Middle cutoff voltage protection • = Low cutoff voltage protection 	<ul style="list-style-type: none"> • = Normal airplane/Glider • = Helicopter 1 (Soft start) • = Helicopter 2 (Soft start + Governor Mode) 	<ul style="list-style-type: none"> • = Standard • = Medium speed • = Quick speed

Instructions on Aircraft Mode Settings

Normal Airplane/Glider Mode (Option 4-1):

This option is applied to general airplanes and gliders.

Helicopter 1 Mode (Option 4-2):

This option provides a soft start feature and is applied to Helicopters for Normal, Idle Up 1, or Idle Up 2 modes. Please note that the sensitivity of the gyro should be set lower when flying in Idle Up 1 or Idle Up 2 modes if tail hunting (wag) occurs due to higher rotor speed.

Helicopter 2 Mode (Option 4-3):

This option supports soft start as well as Governor Mode features and is applied to Helicopters for Idle Up 1 and Idle Up 2 modes(not suitable for Normal Flight Mode). When Governor Mode is in use, the throttle should be set between 75% and 85%. Again if tail wag occurs, lower the sensitivity of the gyro to eliminate the hunting effect. The Governor Mode may not work properly in cases of insufficient rotor speed (due to improper gear ratio), poor battery discharge capability, and improper setting of gyro sensitivity and the blade pitch, etc. Please make sure all the proper adjustments have been done when using Governor Mode.

Setup Mode

Minimum 4 channel radio is required

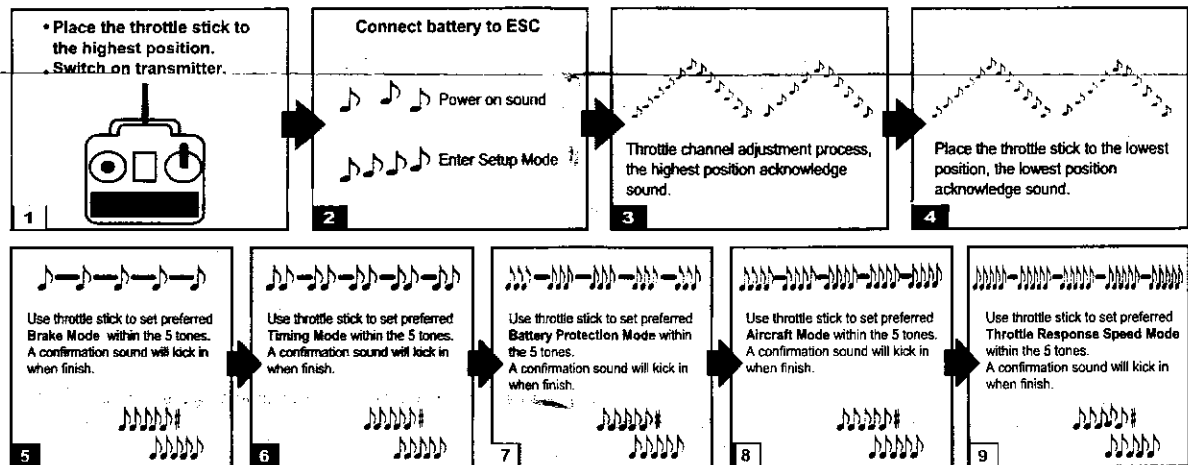

After setup is completed, place the stick to the lowest position, and then take off the battery and plug it on to enter user mode(or wait until the User mode beeps finish). The ESC is ready for use.

G20206 V4